

PROCESS + SPECIALITY

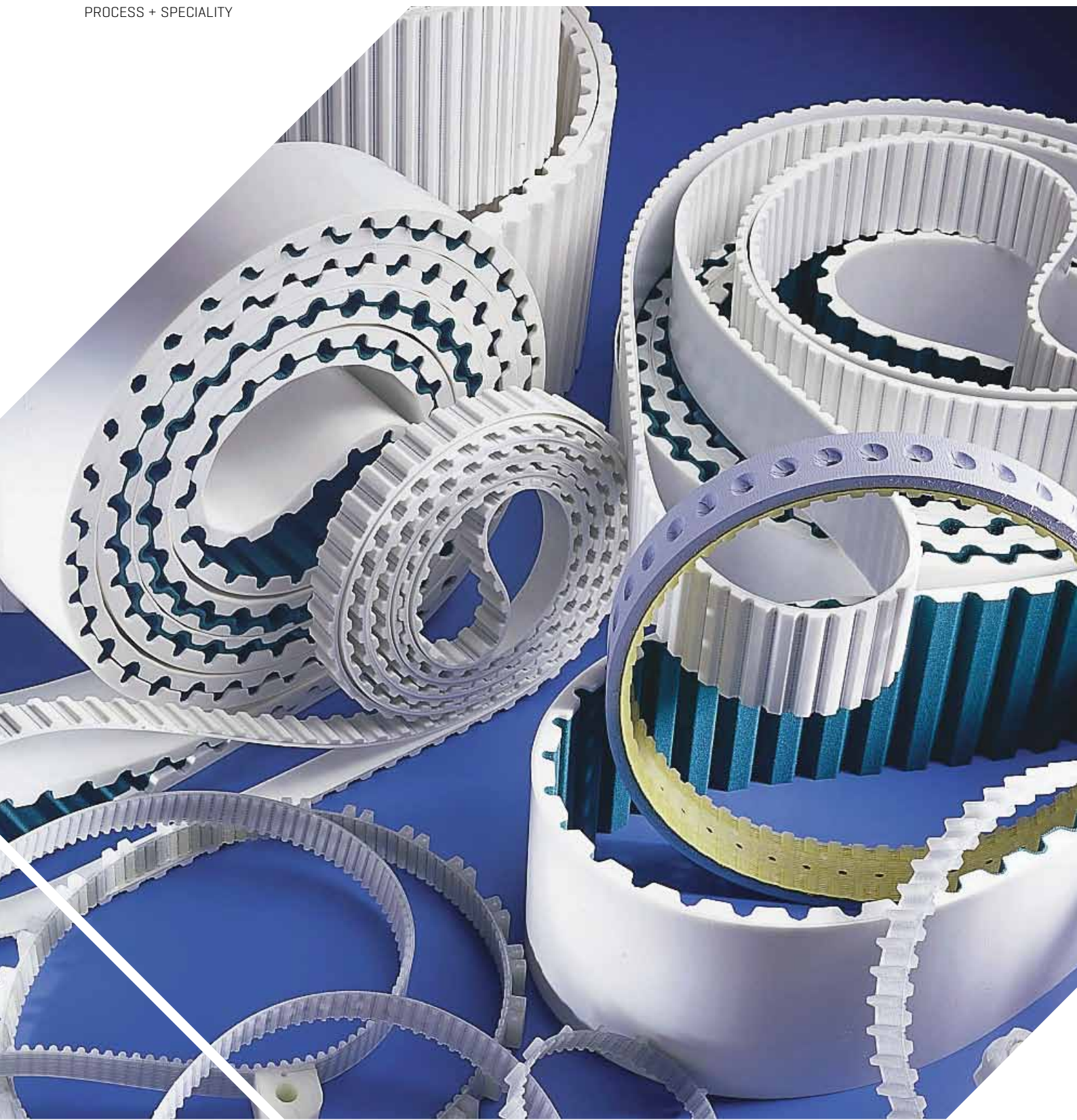

POLYURETHANE BELT PROGRAM

PRODUCT AND TECHNICAL INFORMATION



Company Profile

Gates is a multinational, leading manufacturer of technological forward-looking power transmission and conveyor belts made out of highly abrasion-resistant polyurethane used in various industries and applications.

Gates Polyurethane Timing Belts provide long-lasting, energy-efficient solutions for power transmission and linear applications. Available are open ended and truly endless belts with different sizes, designs and tooth shapes for various applications.

For processes requiring a specific belt design, contact Gates. Gates offers a variety of customized polyurethane belts to meet the most challenging requirements.

Our Service

With production and distribution partners worldwide Gates offers global service to solve your challenges. As a total integrated facility, Gates combines in-house extrusion, Molding as well as fabrication capabilities.

Our Quality

Specialization, research and quality control are the basis of Gates success. Gates keeps investing in quality, research and development in order to meet its customer's current and future demands. Our continuous development of our products and plants guarantees highest quality according to ISO 9001, ISO 14001 and ISO 18001.

REACH - Registration, Evaluation, Authorization of Chemical substances

Gates takes its responsibility for human health and the environment very seriously and complies with the requirements laid down in the REACH regulation. All substances in our belts requiring registration will be duly registered in the central database run by the European Chemicals Agency (ECHA).

CONTENT

POLYURETHANE BELTS	Page	4
TOOTH PROFILES	Page	6
LINEAR BELTS		
Timing Belts	Page	8
Overview Timing Belts Constructions	Page	9
Metric Timing Belts	Page	10
Imperial Timing Belts	Page	48
Self Tracking Timing Belts	Page	56
Flat Belts BLACK-FLAT	Page	74
Overview Flat Belts Constructions	Page	75
Clamp Connection FIX-FLAT	Page	84
Wide Belts	Page	86
Overview Wide Belts Constructions	Page	87
ENDLESS BELTS		
Gates Synchro-Power® Endless Timing Belts	Page	94
Endless FlexTiming Belts	Page	110
FINISHING		
Backings	Page	124
Polyurethane (PU)	Page	126
Rubber Backings.....	Page	128
Foam Backings	Page	130
Polyvinylchlorid (PVC)	Page	132
Special Backings.....	Page	134
Polyamide Fabric.....	Page	134
Overview Backings	Page	136
Profiled Belts	Page	138
Design Recommendations.....	Page	140
Profile Selector	Page	145
Special Finishing	Page	146
INFORMATION		
Technical Design	Page	148
General Information and Abbreviations	Page	162

POLYURETHANE BELT PROGRAM



POLYURETHANE BELTS

Our product quality is highlighted in the details. — Narrow tolerances and perfect tooth engagement are guaranteed.

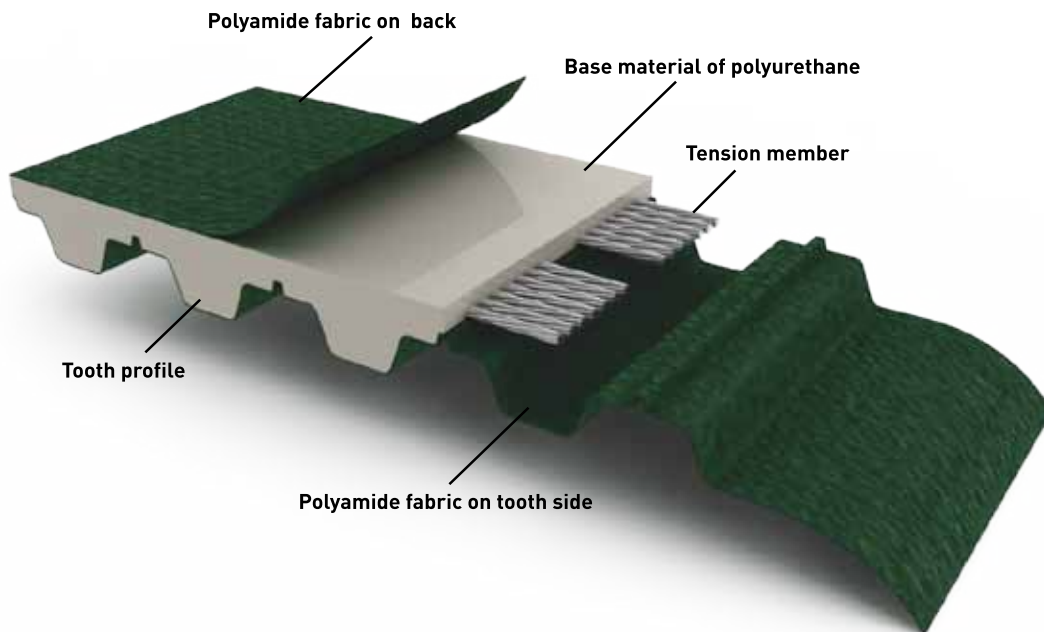



Gates Polyurethane Timing Belts are made out of high quality, abrasion-resistant polyurethane in combination with high strength steel or aramid cords. Nearly every extruded belt type can be additionally customized by adding coatings and profiles or special machining.

ATTRIBUTES

- › Low-maintenance polyurethane construction
- › High tensile strength
- › Abrasion and UV resistant
- › Low pre-tension
- › Excellent durability vs. moisture
- › Temperature resistant from -5° C up to +70° C
Extended service temperature range is available on request

CHEMICAL ATTRIBUTES

- › Non-aging
- › High chemical resistance
- › High durability vs. detergent
- › Excellent durability vs. oil and fat
- › Conditionally permanent vs. acids and bases

TECHNICAL DATA-COEFFICIENT OF FRICTION

› Polyurethane	vs. Steel	dry	0.5	up to 0.7
› Polyurethane	vs. Aluminum	dry	0.5	up to 0.6
› Polyurethane	vs. UHMWPE	dry	0.2	up to 0.4
› Polyamide	vs. Steel	dry	0.2	up to 0.4
› Polyamide	vs. UHMWPE	dry	0.1	up to 0.3
› ECO fabric	vs. Steel	dry	0.1	up to 0.3
› ECO fabric	vs. PE-UHMW	dry	0.05	up to 0.15



TOOTH PROFILES

IMPERIAL TOOTH PROFILE



- PITCH: XL / L / H / XH
- Attributes: > Low tooth profiles with large surface area
- Applications: > Sliding conveyor applications

T TOOTH PROFILE



- PITCH: T2.5 / T5 / T10 / T20
- Attributes: > Developed to enable higher load carrying
> Capacity combined with low backlash
- Applications: > Sliding conveyor applications

AT TOOTH PROFILE



- PITCH: AT5 / AT10 / AT20
- Attributes: > Developed to enable higher load carrying
> Capacity combined with low backlash
- Applications: > Linear positioning
> Power transmission

HTD® TOOTH PROFILE



- PITCH: HTD®5 / HTD®8 / HTD®14
- Attributes: > Higher tooth meshing
> Equal tension distribution and load transmission
> Reduced wear and noise characteristics
- Applications: > Linear / rotary positioning
> Power transmission

HPL® TOOTH PROFILE

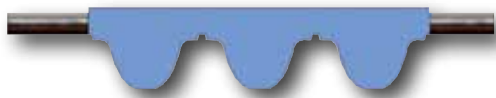

- PITCH: HPL®14
- Attributes:
- › High-performance synchronous belt
 - › PolyChain® 14M tooth shape
 - › Higher carrying capacity due to PCGT14 pulley
- Applications:
- › Linear positioning
 - › Lifting

STD TOOTH PROFILE

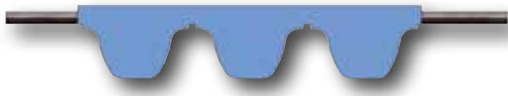

- PITCH: STD5 / STD8
- Attributes:
- › Reduced wear and noise characteristics
- Applications:
- › Linear positioning
 - › Power transmission

FLAT BELTS



- PITCH: BFL20 / BFL32 / BFL38 / BFL48
- Attributes:
- › Easy belt guiding
 - › Small pulley diameters
- Applications:
- › Lifting

WIDE BELTS



- PITCH: WT10 / WH / GMT3™
- Attributes:
- › Widths up to 450mm available
 - › Alternative to plastic modular chains and flat belting
- Applications:
- › Synchronous conveying
 - › Food industry applications

LINEAR BELTS

TIMING BELTS

TIMING BELTS

SELF TRACKING

FLAT BELTS

WIDE BELTS

ENDLESS BELTS

FINISHING

INFORMATION

Gates Linear Timing belts are manufactured in different sizes, constructions and tooth shapes. The wide range of various constructions offers the exact solution for quite every application. Linear belts are available in different types, such as roll stock, open ended (long length), pre-punched or endless, thermal welded belts.

Gates linear belts are designed to ensure high class performance for both, power transmission and linear applications. And they are suitable for a broad range of demands, speeds and applications.

ATTRIBUTES

- › Thermoplastic polyurethane construction
- › High tensile strength and stiffness
- › Parallel cord construction for uniform tensioning
- › Smooth, low-noise operation
- › Temperature range from -5° C up to +70° C
- › Extended service temperature range is available on request
- › FDA Approval for:
XL / L / H / T5 / T10 / AT10 / WT10 / WH / BFL20-Aramid / BFL20-RKV / BFL32-Aramid / BFL32-RKV
- › EU Food Approval for:
T5 / AT5 / T10 / AT10 / GMT3™ / WT10 / WH / WR10

APPLICATIONS

- › Conveying- and handling equipment
- › Linear applications
- › Synchronous conveying applications
- › Automatic assembly machines
- › Door drives
- › Textile industry

PROCESSING OPTIONS

- › Backings *Further information on page 124*
- › Profile *Further information on page 138*
- › Special processing *Further information on page 146*

LINEAR TIMING BELTS	TENSION MEMBER							POLYURETHANE					FABRIC BACKINGS					Page		
	Steel-Standard	Steel-High Flexible (HF)	Steel-Reinforced (RSL)	Steel-Reinforced High Flexible (RHF)	Steel-Basic (BASIC)	Stainless Steel-(NIRO)	Aramid-(KV)	Aramid-Reinforced (RKV)	R1-92 Shore A	R2-85 Shore A	R4-94 Shore A / Antistatic	EU-85-85 Shore A / EU-Approval	EU-92-92 Shore A / EU-Approval	FDA-Approval	ECO Fabric	NT-Polyamide Fabric on Tooth Side	NB-Polyamide Fabric on Back		NTB-Polyamide Fabric on both Sides	ATB-Antistatic Fabric both Sides
METRIC TIMING BELTS																				
T5	●						●	●	●	●	●	●	●	●	●	●	●	●	●	10
T10	●	●					●	●	●	●	●	●	●	●	●	●	●	●	●	12
T20	●	●				●	●	●	●	●	●	●	●	●	●	●	●	●	●	14
AT5	●						●	●	●	●	●	●	●	●	●	●	●	●	●	16
ATL5			●				●	●						●	●	●	●	●	●	18
AT10	●	●				●	●	●	●	●	●	●	●	●	●	●	●	●	●	20
ATL10			●	●			●	●	●	●	●	●	●	●	●	●	●	●	●	22
AT20	●						●	●	●	●	●	●	●	●	●	●	●	●	●	24
ATL20			●				●	●	●					●	●	●	●	●	●	26
HTD [®] 5	●				●	●	●	●	●	●	●	●	●	●	●	●	●	●	●	28
HTD [®] 8	●	●				●	●	●	●	●	●	●	●	●	●	●	●	●	●	30
HTD [®] L8			●	●			●	●	●	●	●	●	●	●	●	●	●	●	●	32
HTD [®] 14	●	●					●	●	●	●	●	●	●	●	●	●	●	●	●	34
HTD [®] L14			●				●	●	●	●	●	●	●	●	●	●	●	●	●	36
STD5	●						●	●			●	●	●	●	●	●	●	●	●	38
STD8	●	●				●	●	●	●	●	●	●	●	●	●	●	●	●	●	40
HPL [®] 14-RSL			●				●	●	●					●	●	●	●	●	●	42
T5-ATB	●						●	●	●									●		44
WR10	●	●					●	●	●	●	●				●					46
IMPERIAL TIMING BELTS																				
XL	●						●	●	●	●	●	●	●	●	●	●	●	●	●	48
L	●						●	●					●	●	●	●	●	●	●	50
H	●	●					●	●	●	●	●	●	●	●	●	●	●	●	●	52
XH	●						●	●				●	●	●	●	●	●	●	●	54
SELF TRACKING TIMING BELTS																				
T5V	●						●	●	●	●	●	●	●	●	●	●	●	●	●	60
AT5V	●						●	●							●					62
ATL5V	●						●	●							●					64
T10VS	●						●	●				●			●					66
T10V	●						●	●				●			●					68
AT10V	●	●				●	●	●	●	●	●	●	●	●	●	●	●	●	●	70
HV	●						●	●				●			●					72

- STANDARD
- ON REQUEST

Specifications can change without prior notice.
Please contact our Applications Engineering for specific „minus“ and length tolerances.
For further configurations please contact our Application Consulting.
Please find used abbreviations on page 162.

LINEAR BELTS

METRIC TIMING BELTS

TIMING BELTS

SELF-TRACKING

FLAT BELTS

WIDE BELTS

ENDLESS BELTS

FINISHING

INFORMATION



Pitch	5 mm
Standard Color	White
Standard Roll Length ($\pm 1\%$)	100 m
Width Tolerance up to 50 mm Width > 50 mm Width	± 0.5 mm ± 0.75 mm
Sitting Lanes Standard Optional	25 mm 10 mm / 16 mm
Minimum Welded Belt Length	480 mm
Minimum Number of Pulley Teeth z_{\min}	10
Minimum Pulley Diameter	15.91 mm
Minimum Back Bend Diameter	30 mm
FDA/EU Approval	Yes (Aramid Cord)

T5

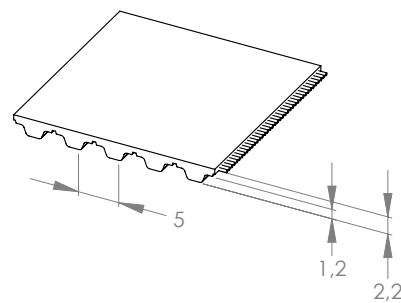

Standard Width (mm)	10	16	25	32	50	75	100
Tensile Strength (Average Value) F_{Break} (N)							
Steel	1 250	2 000	3 375	4 250	6 875	10 375	13 875
Aramid	3 162	5 245	8 370	10 800	17 050	25 730	34 410
Allowable Belt Force F_{1all} (N) Open Ended							
Steel	311	498	840	1 058	1 711	2 582	3 453
Aramid	346	574	916	1 181	1 865	2 814	3 764
Allowable Belt Force F_{1all} (N) Endless Welded							
Steel	156	249	420	529	856	1 291	1 727
Aramid	259	430	687	886	1 399	2 111	2 823
Allowable Effective Force F_{eall} (N)							
(Minimum 15 teeth are in mesh)	356	570	890	1 139	1 780	2 670	3 560
Specific Belt Mass m_{sp} (kg/m/mm)							
Steel	0.0022						
Aramid	0.0020						
Specific Belt Stiffness c_{sp} (N)							
Steel	77 778	124 444	210 000	264 444	427 778	645 556	863 333
Aramid	86 464	143 428	228 875	295 334	466 227	703 579	940 931

TIMING BELTS

SELF TRACKING

FLAT BELTS

WIDE BELTS

ENDLESS BELTS

FINISHING

INFORMATION

LINEAR BELTS

METRIC TIMING BELTS

TIMING BELTS

SELF TRACKING

FLAT BELTS

WIDE BELTS

ENDLESS BELTS

FINISHING

INFORMATION



Pitch	10 mm
Standard Color	White
Standard Roll Length ($\pm 1\%$)	100 m
Width Tolerance	
up to 50 mm Width	± 0.5 mm
> 50 mm Width	± 0.75 mm
Sitting Lanes	
Standard	25 mm
Optional	10 mm / 16 mm
Minimum Welded Belt Length	
up to 100 mm Width	480 mm
> 100 mm Width	960 mm
Minimum Number of Pulley Teeth z_{\min}	14 (Steel/Aramid) 12 (HF)
Minimum Pulley Diameter	44,56 mm (Steel/Aramid) 38,20 mm (HF)
Minimum Back Bend Diameter	80 mm (Steel/Aramid) 60 mm (HF)
FDA/EU Approval	Yes (Aramid Cord)

T10

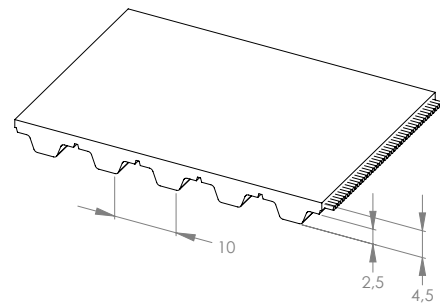

Standard Width (mm)	12	16	25	32	40	50	75	100	150
Tensile Strength (Average Value) F_{Break} (N)									
Steel	2 940	4 200	7 140	9 240	11 340	14 700	22 260	29 820	44 940
Aramid	3 601	4 980	8 085	10 500	13 259	16 709	25 333	33 957	51 205
HF	4 340	6 200	10 540	13 640	16 740	21 700	32 860	44 020	66 340
Allowable Belt Force F_{1all} (N) Open Ended									
Steel	786	1 123	1 909	2 470	3 031	3 929	5 950	7 971	12 012
Aramid	474	655	1 064	1 381	1 744	2 198	3 332	4 467	6 736
HF	964	1 376	2 340	3 028	3 716	4 818	7 295	9 773	14 728
Allowable Belt Force F_{1all} (N) Endless Welded									
Steel	393	561	954	1 235	1 516	1 965	2 975	3 985	6 006
Aramid	355	491	798	1 036	1 308	1 648	2 499	3 350	5 052
HF	482	688	1 170	1 514	1 858	2 409	3 648	4 886	7 364
Allowable Effective Force F_{eall} (N)									
(Minimum 15 teeth are in mesh)	811	1 082	1 690	2 163	2 704	3 380	5 070	6 760	10 140
Specific Belt Mass m_{sp} (kg/m/mm)									
Steel	0.0044								
Aramid	0.0036								
HF	0.0047								
Specific Belt Stiffness c_{sp} (N)									
Steel	196 463	280 662	477 125	617 456	757 787	982 316	1 487 507	1 992 699	3 003 081
Aramid	118 403	163 779	265 875	345 283	436 035	549 475	833 075	1 116 675	1 683 875
HF	240 882	344 118	585 000	757 059	929 118	1 204 412	1 823 824	2 443 235	3 682 059

TIMING BELTS

SELF TRACKING

FLAT BELTS

WIDE BELTS

ENDLESS BELTS

FINISHING

INFORMATION

LINEAR BELTS

METRIC TIMING BELTS

TIMING BELTS

SELF TRACKING

FLAT BELTS

WIDE BELTS

ENDLESS BELTS

FINISHING

INFORMATION

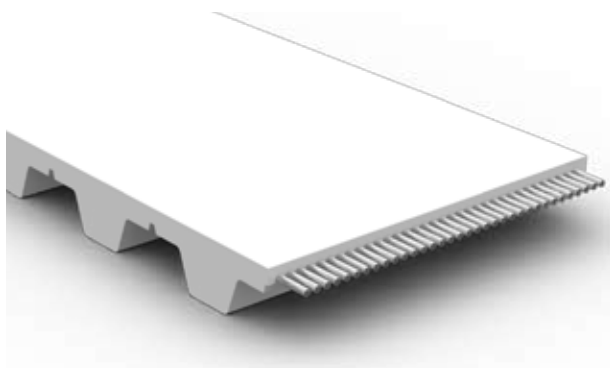

Pitch	20 mm
Standard Color	White
Standard Roll Length ($\pm 1\%$)	50 m
Width Tolerance	± 1.0 mm
Sitting Lanes	
Standard	25 mm
Optional	16 mm
Minimum Welded Belt Length	1 000 mm
Minimum Number of Pulley Teeth z_{min}	15 (Steel/Aramid) 20 (Niro) 12 (HF)
Minimum Pulley Diameter	95,5 mm (Steel/Aramid) 127,4 mm (Niro) 76,4 mm (HF)
Minimum Back Bend Diameter	120 mm (Steel/Aramid) 160 mm (Niro) 100 mm (HF)
FDA/EU Approval	No

T20

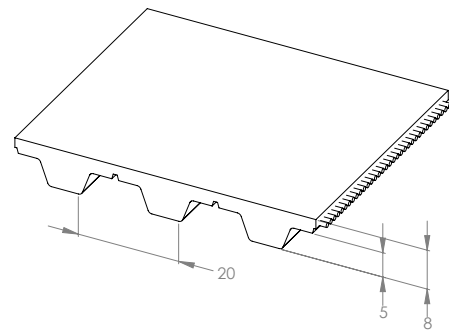

Standard Width (mm)	25	32	50	75	100	150
Tensile Strength (Average Value) F_{Break} (N)						
Steel	14 250	18 050	29 450	44 650	59 850	90 250
Aramid	16 185	21 019	33 449	50 713	67 977	102 505
Niro	10 688	13 538	22 088	33 488	44 888	67 688
HF	12 975	16 435	26 815	40 655	54 495	82 175
Allowable Belt Force F_{1all} (N) Open Ended						
Steel	3 741	4 739	7 731	11 722	15 712	23 693
Aramid	1 750	2 273	3 617	5 483	7 350	11 083
Niro	2 806	3 554	5 799	8 791	11 784	17 770
HF	3 456	4 378	7 142	10 829	14 515	21 888
Allowable Belt Force F_{1all} (N) Endless Welded						
Steel	1 871	2 369	3 866	5 861	7 856	11 847
Aramid	1 313	1 705	2 713	4 113	5 513	8 313
Niro	1 403	1 777	2 899	4 396	5 892	8 885
HF	1 728	2 189	3 571	5 414	7 258	10 944
Allowable Effective Force F_{eall} (N)						
(Minimum 15 teeth are in mesh)	3 160	4 045	6 320	9 480	12 640	18 960
Specific Belt Mass m_{sp} (kg/m/mm)						
Steel			0.0075			
Aramid			0.0059			
Niro			0.0074			
HF			0.0072			
Specific Belt Stiffness c_{sp} (N)						
Steel	935 250	1 184 650	1 932 850	2 930 450	3 928 050	5 923 250
Aramid	437 500	568 167	904 167	1 370 833	1 837 500	2 770 833
Niro	701 438	888 488	1 449 638	2 197 838	2 946 038	4 442 438
HF	864 000	1 094 400	1 785 600	2 707 200	3 628 800	5 472 000

LINEAR BELTS

METRIC TIMING BELTS

TIMING BELTS

SELF-TRACKING

FLAT BELTS

WIDE BELTS

ENDLESS BELTS

FINISHING

INFORMATION



Pitch	5 mm
Standard Color	White
Standard Roll Length ($\pm 1\%$)	100 m
Width Tolerance up to 50 mm Width > 50 mm Width	± 0.5 mm ± 0.75 mm
Sitting Lanes Standard Optional	25 mm 10 mm / 16 mm
Minimum Welded Belt Length	480 mm
Minimum Number of Pulley Teeth z_{\min}	15
Minimum Pulley Diameter	23.87 mm
Minimum Back Bend Diameter	60 mm
FDA/EU Approval	Yes (Aramid Cord)

AT5

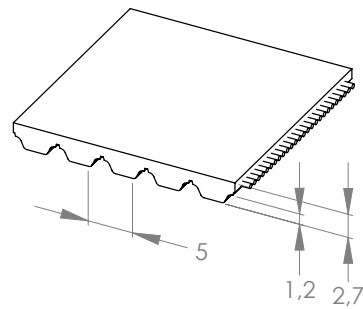

Standard Width (mm)	10	16	25	32	50	75	100
Tensile Strength (Average Value) F_{Break} (N)							
Steel	2 565	4 275	7 125	9 120	14 535	21 945	29 355
Aramid	3 140	5 224	8 350	10 782	17 034	25 718	34 402
Allowable Belt Force F_{1all} (N) Open Ended							
Steel	634	1 056	1 761	2 253	3 591	5 422	7 253
Aramid	455	757	1 210	1 562	2 468	3 727	4 985
Allowable Belt Force F_{1all} (N) Endless Welded							
Steel	317	528	880	1 127	1 796	2 711	3 627
Aramid	341	568	908	1 172	1 851	2 795	3 739
Allowable Effective Force F_{eall} (N) (Minimum 15 teeth are in mesh)							
	516	826	1 290	1 651	2 580	3 870	5 160
Specific Belt Mass m_{sp} (kg/m/mm)							
Steel	0.0033						
Aramid	0.0027						
Specific Belt Stiffness c_{sp} (N)							
Steel	158 445	264 075	440 125	563 360	897 855	1 355 585	1 813 315
Aramid	113 740	189 244	302 500	390 588	617 100	931 700	1 246 300

TIMING BELTS

SELF TRACKING

FLAT BELTS

WIDE BELTS

ENDLESS BELTS

FINISHING

INFORMATION

LINEAR BELTS

METRIC TIMING BELTS

TIMING BELTS

SELF TRACKING

FLAT BELTS

WIDE BELTS

ENDLESS BELTS

FINISHING

INFORMATION

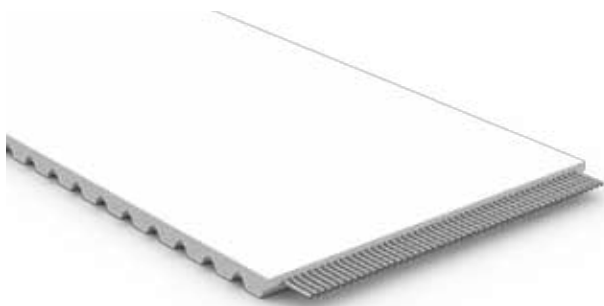

Pitch	5 mm
Standard Color	White
Standard Roll Length ($\pm 1\%$)	100 m
Width Tolerance up to 50 mm Width > 50 mm Width	± 0.5 mm ± 0.75 mm
Sitting Lanes Standard Optional	25 mm 10 mm / 16 mm
Minimum Welded Belt Length	No Welding
Minimum Number of Pulley Teeth z_{\min}	15
Minimum Pulley Diameter	23.87 mm
Minimum Back Bend Diameter	60 mm
FDA/EU Approval	No

ATL5

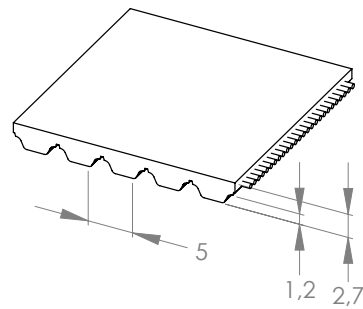

Standard Width (mm)	10	16	25	32	50	75	100	150
Tensile Strength (Average Value) F_{Break} (N)								
Steel	3 720	6 200	10 540	13 640	21 700	32 860	44 020	66 340
Allowable Belt Force F_{1all} (N) Open Ended								
Steel	826	1 376	2 340	3 028	4 818	7 295	9 773	14 728
Allowable Effective Force F_{eall} (N)								
(Minimum 15 teeth are in mesh)	516	826	1 290	1 651	2 580	3 870	5 160	7 740
Specific Belt Mass m_{sp} (kg/m/mm)								
Steel	0.0028							
Specific Belt Stiffness c_{sp} (N)								
Steel	206 471	344 118	585 000	757 059	1 204 412	1 823 824	2 443 235	3 682 059

TIMING BELTS

SELF TRACKING

FLAT BELTS

WIDE BELTS

ENDLESS BELTS

FINISHING

INFORMATION

LINEAR BELTS

METRIC TIMING BELTS

TIMING BELTS

SELF-TRACKING

FLAT BELTS

WIDE BELTS

ENDLESS BELTS

FINISHING

INFORMATION

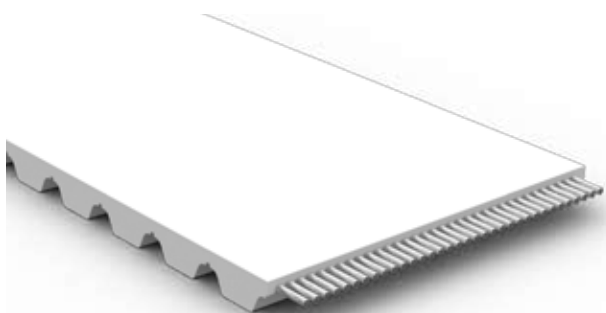

Pitch	10 mm
Standard Color	White
Standard Roll Length ($\pm 1\%$)	100 m
Width Tolerance	
up to 50 mm Width	± 0.75 mm
> 50 mm Width	± 1.0 mm
Sitting Lanes	
Standard	25 mm
Optional	16 mm
Minimum Welded Belt Length	
up to 100 mm Width	480 mm
> 100 mm Width	960 mm
Minimum Number of Pulley Teeth z_{\min}	15 (Steel/Aramid) 20 (Niro) 12 (HF)
Minimum Pulley Diameter	47.75 mm (Steel/Aramid) 63.7 mm (Niro) 39 mm (HF)
Minimum Back Bend Diameter	120 mm (Steel/Aramid) 160 mm (Niro) 100 mm (HF)
FDA/EU Approval	Yes (Aramid Cord)

AT10

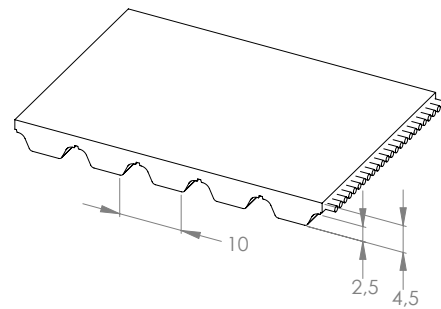

Standard Width (mm)	16	25	32	50	75	100	150
Tensile Strength (Average Value) F_{Break} (N)							
Steel	8 550	14 250	18 050	29 450	44 650	59 850	90 250
Aramid	9 970	16 185	21 019	33 449	50 713	67 977	102 505
Niro	6 413	10 688	13 538	22 088	33 488	44 888	67 668
HF	7 785	12 975	16 435	26 815	40 655	54 495	82 175
Allowable Belt Force F_{1all} (N) Open Ended							
Steel	2 245	3 741	4 739	7 731	11 722	15 712	23 693
Aramid	1 078	1 750	2 273	3 617	5 483	7 350	11 083
Niro	1 683	2 806	3 554	5 799	8 791	11 784	17 770
HF	2 074	3 456	4 378	7 142	10 829	14 515	21 888
Allowable Belt Force F_{1all} (N) Endless Welded							
Steel	1 122	1 871	2 369	3 866	5 861	7 856	11 847
Aramid	809	1 313	1 705	2 713	4 113	5 513	8 313
Niro	842	1 403	1 777	2 899	4 396	5 892	8 885
HF	1 037	1 728	2 189	3 571	5 414	7 258	10 944
Allowable Effective Force F_{eall} (N)							
(Minimum 15 teeth are in mesh)	1 651	2 580	3 302	5 160	7 740	10 320	15 480
Specific Belt Mass m_{sp} (kg/m/mm)							
Steel				0.0057			
Aramid				0.0042			
Niro				0.0057			
HF				0.0055			
Specific Belt Stiffness c_{sp} (N)							
Steel	561 150	935 250	1 184 650	1 932 850	2 930 450	3 928 050	5 923 250
Aramid	269 500	437 500	568 167	904 167	1 370 833	1 837 500	2 770 833
Niro	420 863	701 438	888 488	1 449 638	2 197 838	2 946 038	4 442 438
HF	518 400	864 000	1 094 400	1 785 600	2 707 200	3 628 800	5 472 000

LINEAR BELTS

METRIC TIMING BELTS

TIMING BELTS

SELF-TRACKING

FLAT BELTS

WIDE BELTS

ENDLESS BELTS

FINISHING

INFORMATION

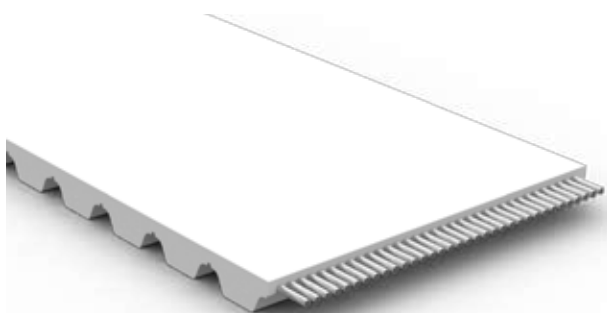

Pitch	10 mm
Standard Color	White
Standard Roll Length ($\pm 1\%$)	100 m
Width Tolerance	
up to 50 mm Width	± 1.0 mm
> 50 mm Width	± 1.5 mm
Sitting Lanes	
Standard	Without Sitting Lanes
Optional	25 mm / 32 mm / 50 mm
Minimum Welded Belt Length	No Welding
Minimum Number of Pulley Teeth z_{min}	25 (Steel/Aramid) 20 (HF)
Minimum Pulley Diameter	79.60 mm (Steel/Aramid) 63.66 mm (HF)
Minimum Back Bend Diameter	150 mm (Steel/Aramid) 130 mm (HF)
FDA/EU Approval	No

ATL10

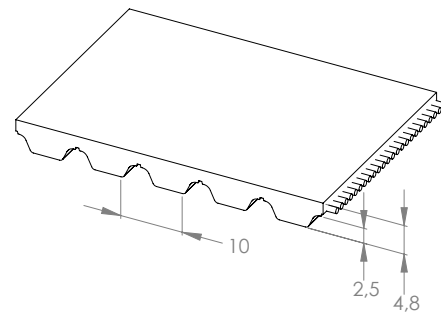

Standard Width (mm)	16	25	32	50	75	100	150
Tensile Strength (Average Value) F_{Break} (N)							
Steel	13 840	24 220	31 140	50 170	76 120	102 070	153 970
Aramid	13 390	21 798	28 337	45 153	68 508	91 863	138 573
HF	15 400	26 950	34 650	55 825	84 700	113 575	171 325
Allowable Belt Force F_{1all} (N) Open Ended							
Steel	3 349	5 860	7 534	12 139	18 417	24 696	37 253
Aramid	1 075	1 750	2 275	3 625	5 500	7 375	11 125
HF	2 902	5 079	6 530	10 521	15 963	21 404	32 288
Allowable Effective Force F_{eall} (N)							
(Minimum 15 teeth are in mesh)	1 651	2 580	3 302	5 160	7 740	10 320	15 480
Specific Belt Mass m_{sp} (kg/m/mm)							
Steel	0.0067						
Aramid	0.0041						
HF	0.0072						
Specific Belt Stiffness c_{sp} (N)							
Steel	837 143	1 465 000	1 883 571	3 034 643	4 604 286	6 173 929	9 313 214
Aramid	268 750	437 500	568 750	906 250	1 375 000	1 843 750	2 781 250
HF	725 571	1 269 750	1 632 536	2 630 196	3 990 643	5 351 089	8 071 982

TIMING BELTS

SELF TRACKING

FLAT BELTS

WIDE BELTS

ENDLESS BELTS

FINISHING

INFORMATION

LINEAR BELTS

METRIC TIMING BELTS

TIMING BELTS

SELF-TRACKING

FLAT BELTS

WIDE BELTS

ENDLESS BELTS

FINISHING

INFORMATION



Pitch	20 mm
Standard Color	White
Standard Roll Length ($\pm 1\%$)	50 m
Width Tolerance	
up to 50 mm Width	± 1.0 mm
> 50 mm Width	± 1.5 mm
Sitting Lanes	
Standard	Without Sitting Lanes
Optional	25 mm / 32 mm
Minimum Welded Belt Length	1.200 mm
Minimum Number of Pulley Teeth z_{\min}	18
Minimum Pulley Diameter	115.6 mm
Minimum Back Bend Diameter	180 mm
FDA/EU Approval	No

AT20

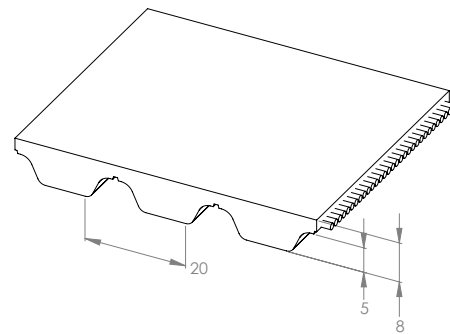

Standard Width (mm)	25	32	50	75	100	150
Tensile Strength (Average Value) F_{Break} (N)						
Steel	24 220	31 140	50 170	76 120	102 070	153 970
Aramid	21 798	28 337	45 153	68 508	91 863	138 573
Allowable Belt Force F_{1all} (N) Open Ended						
Steel	5 860	7 534	12 139	18 417	24 696	37 253
Aramid	1 750	2 275	3 625	5 500	7 375	11 125
Allowable Belt Force F_{1all} (N) Endless Welded						
Steel	2 930	3 767	6 069	9 209	12 348	18 626
Aramid	1 313	1 706	2 719	4 125	5 531	8 344
Allowable Effective Force F_{eall} (N)						
(Minimum 15 teeth are in mesh)	5 430	6 950	10 860	16 290	21 720	32 580
Specific Belt Mass m_{sp} (kg/m/mm)						
Steel	0.0097					
Aramid	0.0073					
Specific Belt Stiffness c_{sp} (N)						
Steel	1 465 000	1 883 571	3 034 643	4 604 286	6 173 929	9 313 214
Aramid	437 500	568 750	906 250	1 375 000	1 843 750	2 781 250

TIMING BELTS

SELF TRACKING

FLAT BELTS

WIDE BELTS

ENDLESS BELTS

FINISHING

INFORMATION

LINEAR BELTS

METRIC TIMING BELTS

TIMING BELTS

SELF TRACKING

FLAT BELTS

WIDE BELTS

ENDLESS BELTS

FINISHING

INFORMATION

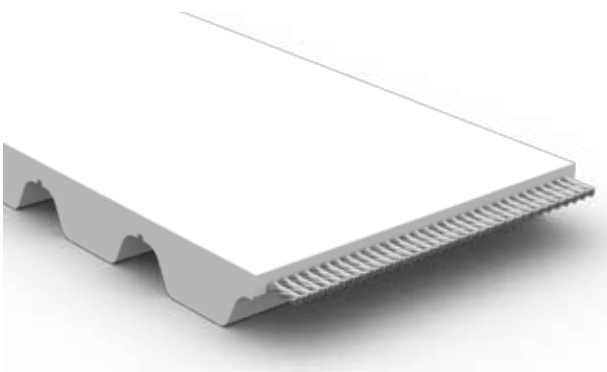

Pitch	20 mm
Standard Color	White
Standard Roll Length ($\pm 1\%$)	50 m
Width Tolerance	± 2.0 mm
Sitting Lanes Standard	Without Sitting Lanes
Optional	50 mm
Minimum Welded Belt Length	No Welding
Minimum Number of Pulley Teeth z_{min}	30
Minimum Pulley Diameter	190.98 mm
Minimum Back Bend Diameter	250 mm
FDA/EU Approval	No

ATL20

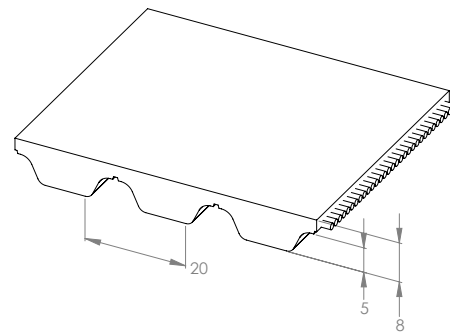

Standard Width (mm)	32	50	75	100	150
Tensile Strength (Average Value) F_{Break} (N)					
Steel	41 600	70 400	105 600	144 000	217 600
Allowable Belt Force F_{1all} (N) Open Ended					
Steel	9 106	15 410	23 115	31 520	47 631
Allowable Effective Force F_{eall} (N)					
(Minimum 15 teeth are in mesh)	6 950	10 860	16 290	21 720	32 580
Specific Belt Mass m_{sp} (kg/m/mm)					
Steel	0.0107				
Specific Belt Stiffness c_{sp} (N)					
Steel	2 276 477	3 852 500	5 778 750	7 880 114	11 907 727

TIMING BELTS

SELF TRACKING

FLAT BELTS

WIDE BELTS

ENDLESS BELTS

FINISHING

INFORMATION

LINEAR BELTS

METRIC TIMING BELTS

TIMING BELTS

SELF-TRACKING

FLAT BELTS

WIDE BELTS

ENDLESS BELTS

FINISHING

INFORMATION

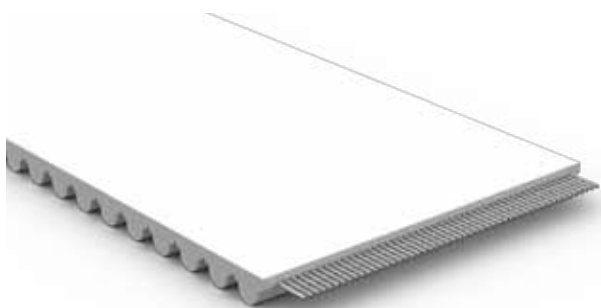

Pitch	5 mm
Standard Color	White
Standard Roll Length ($\pm 1\%$)	100 m
Width Tolerance	
up to 50 mm Width	± 0.5 mm
> 50 mm Width	± 0.75 mm
Sitting Lanes	25 mm
Minimum Welded Belt Length	
up to 100 mm Width	480 mm
> 100 mm Width	960 mm
Minimum Number of Pulley Teeth z_{\min}	14 (Steel Classic/Aramid) 16 (Steel Basic)
Minimum Pulley Diameter	22.28 mm (Steel Classic/Aramid) 25.5 mm (Steel Basic)
Minimum Back Bend Diameter	60 mm (Steel Classic/Aramid) 80 mm (Steel Basic)
FDA/EU Approval	No

HTD®5

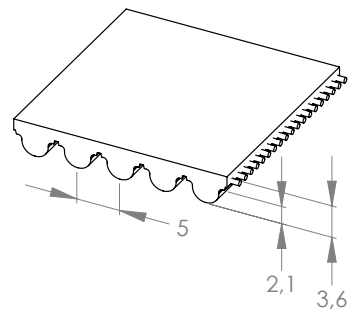

Standard Width (mm)	10	15	20	25	50	100	150
Tensile Strength (Average Value) F_{Break} (N)							
Steel Classic	3 720	5 580	8 060	10 540	21 700	44 020	66 340
Aramid	2 911	4 635	6 360	8 085	16 709	33 957	51 205
Steel Basic	2 520	3 780	5 460	7 140	14 700	29 820	44 940
Allowable Belt Force F_{1all} (N) Open Ended						3 780	
Steel Classic	826	1 239	1 789	2 340	4 818	9 773	14 728
Aramid	383	610	837	1 064	2 198	4 467	6 736
Steel Basic	674	1 010	1 459	1 909	3 929	7 971	12 012
Allowable Belt Force F_{1all} (N) Endless Welded							
Steel Classic	413	619	895	1 170	2 409	4 886	7 364
Aramid	287	457	627	798	1 648	3 350	5 052
Steel Basic	337	505	730	954	1 965	3 985	6 006
Allowable Effective Force F_{eall} (N)							
(Minimum 15 teeth are in mesh)	408	612	816	1 020	2 040	4 080	6 120
Specific Belt Mass m_{sp} (kg/m/mm)							
Steel Classic	0.0049						
Aramid	0.0029						
Steel Basic	0.0044						
Specific Belt Stiffness c_{sp} (N)							
Steel Classic	206 471	309 706	447 353	585 000	1 204 412	2 443 235	3 682 059
Aramid	95 715	152 435	209 155	265 875	549 475	1 116 675	1 683 875
Steel Basic	168 397	252 596	364 860	477 125	982 316	1 992 699	3 003 081

TIMING BELTS

SELF TRACKING

FLAT BELTS

WIDE BELTS

ENDLESS BELTS

FINISHING

INFORMATION

LINEAR BELTS

METRIC TIMING BELTS

TIMING BELTS

SELF TRACKING

FLAT BELTS

WIDE BELTS

ENDLESS BELTS

FINISHING

INFORMATION

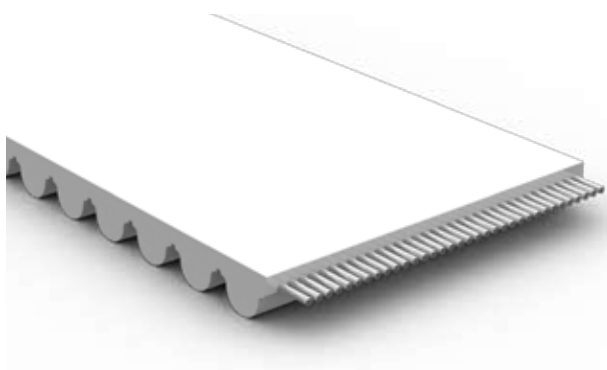

Pitch	8 mm
Standard Color	White
Standard Roll Length ($\pm 1\%$)	100 m
Width Tolerance	
up to 50 mm Width	$\pm 0,75$ mm
> 50 mm Width	$\pm 1,0$ mm
Sitting Lanes	
Standard	25 mm
Optional	10 mm / 16 mm
Minimum Welded Belt Length	
up to 100 mm Width	480 mm
> 100 mm Width	960 mm
Minimum Number of Pulley Teeth z_{min}	20 (Steel/Aramid) 25 (Niro) 16 (HF)
Minimum Pulley Diameter	50,93 mm (Steel/Aramid) 63,7 mm (Niro) 40,8 mm (HF)
Minimum Back Bend Diameter	120 mm (Steel/Aramid) 150 mm (Niro) 100 mm (HF)
FDA/EU Approval	No

HTD® 8

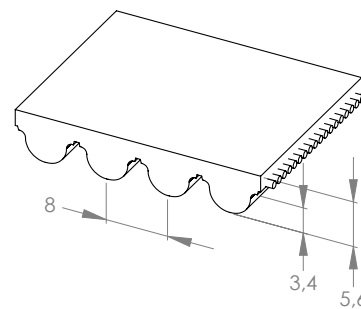

Standard Width (mm)	10	15	20	25	30	50	85	100	150
Tensile Strength (Average Value) F_{Break} (N)									
Steel	4 750	7 600	10 450	14 250	17 100	29 450	50 350	59 850	90 250
Aramid	5 827	9 279	12 732	16 185	19 638	33 449	57 619	67 977	102 505
Niro	3 563	5 700	7 838	10 688	12 825	22 088	37 763	44 888	67 688
HF	4 325	6 920	9 515	12 975	15 570	26 815	45 845	54 495	82 175
Allowable Belt Force F_{1all} (N) Open Ended									
Steel	1 247	1 995	2 743	3 741	4 489	7 731	13 218	15 712	23 693
Aramid	630	1003	1 377	1 750	2 123	3 617	6 230	7 350	11 083
Niro	935	1 496	2 058	2 806	3 367	5 799	9 914	11 784	17 770
HF	1 152	1 843	2 534	3 456	4 147	7 142	12 211	14 515	21 888
Allowable Belt Force F_{1all} (N) Endless Welded									
Steel	624	998	1 372	1 871	2 245	3 866	6 609	7 856	11 847
Aramid	473	753	1 033	1 313	1 593	2 713	4 673	5 513	8 313
Niro	468	748	1 029	1 403	1 683	2 899	4 957	5 892	8 885
HF	576	922	1 267	1 728	2 074	3 571	6 106	7 258	10 944
Allowable Effective Force F_{eall} (N)									
(Minimum 15 teeth are in mesh)	748	1 122	1 496	1 870	2 244	3 740	6 358	7 480	11 220
Specific Belt Mass m_{sp} (kg/m/mm)									
Steel	0.0069								
Aramid	0.0047								
Niro	0.0068								
HF	0.0066								
Specific Belt Stiffness c_{sp} (N)									
Steel	311 750	498 800	685 850	935 250	1 122 300	1 932 850	3 304 550	3 928 050	5 923 250
Aramid	157 500	250 833	344 167	437 500	530 833	904 167	1 557 500	1 837 500	2 770 833
Niro	233 813	374 100	514 388	701 438	841 725	1 449 638	2 478 413	2 946 038	4 442 438
HF	288 000	460 800	633 600	864 000	1 036 800	1 785 600	3 052 800	3 628 800	5 472 000

LINEAR BELTS

METRIC TIMING BELTS

TIMING BELTS

SELF-TRACKING

FLAT BELTS

WIDE BELTS

ENDLESS BELTS

FINISHING

INFORMATION

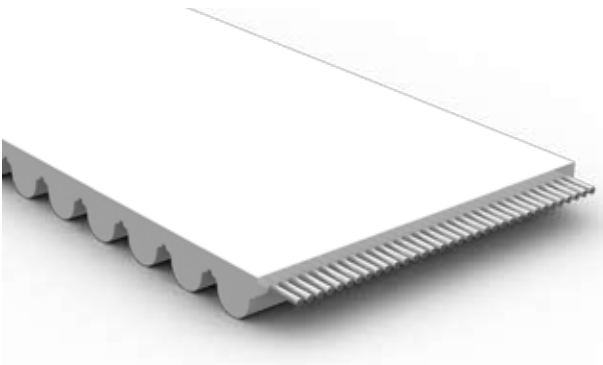

Pitch	8 mm
Standard Color	White
Standard Roll Length ($\pm 1\%$)	100 m
Width Tolerance	
up to 50 mm Width	± 1.0 mm
> 50 mm Width	± 1.5 mm
Sitting Lanes	Without Sitting Lanes
Minimum Welded Belt Length	No Welding
Minimum Number of Pulley Teeth z_{min}	32 (Steel/Aramid) 25 (HF)
Minimum Pulley Diameter	81.48 mm (Steel/Aramid) 63.66 mm (HF)
Minimum Back Bend Diameter	150 mm (Steel/Aramid) 130 mm (HF)
FDA/EU Approval	No

HTD® L8

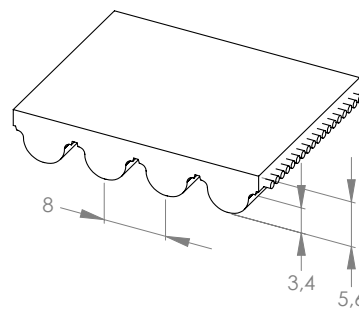

Standard Width (mm)	20	25	30	50	85	100	150
Tensile Strength (Average Value) F_{Break} (N)							
Steel	19 030	24 220	29 410	50 170	86 500	102 070	153 970
Aramid	17 127	21 798	26 469	45 153	77 850	91 863	138 573
HF	21 175	26 950	32 725	55 825	96 250	113 575	171 325
Allowable Belt Force F_{1all} (N) Open Ended							
Steel	4 604	5 860	7 116	12 139	20 929	24 696	37 253
Aramid	1 375	1 750	2 125	3 625	6 250	7 375	11 125
HF	3 991	5 079	6 167	10 521	18 139	21 404	32 288
Allowable Effective Force F_{eall} (N)							
(Minimum 15 teeth are in mesh)	1 496	1 870	2 244	3 740	6 358	7 480	11 220
Specific Belt Mass m_{sp} (kg/m/mm)							
Steel				0.0079			
Aramid				0.0045			
HF				0.0083			
Specific Belt Stiffness c_{sp} (N)							
Steel	1 151 071	1 465 000	1 778 929	3 034 643	5 232 143	6 173 929	9 313 214
Aramid	343 750	437 500	531 250	906 250	1 562 500	1 843 750	2 781 250
HF	997 661	1 269 750	1 541 839	2 630 196	4 534 821	5 351 089	8 071 982

TIMING BELTS

SELF TRACKING

FLAT BELTS

WIDE BELTS

ENDLESS BELTS

FINISHING

INFORMATION

LINEAR BELTS

METRIC TIMING BELTS

TIMING BELTS

SELF-TRACKING

FLAT BELTS

WIDE BELTS

ENDLESS BELTS

FINISHING

INFORMATION

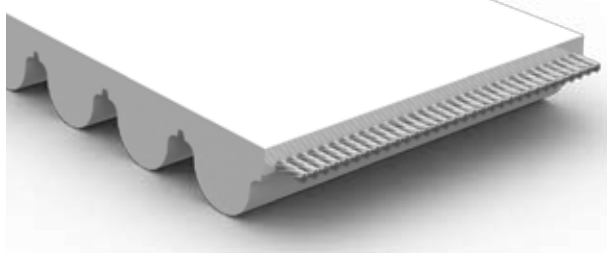

Pitch	14 mm
Standard Color	White
Standard Roll Length ($\pm 1\%$)	50 m
Width Tolerance	
up to 50 mm Width	± 1.0 mm
> 50 mm up to 100 mm Width	± 1.5 mm
> 100 mm Width	± 2.0 mm
Sitting Lanes	
Standard	55 mm
Optional	85 mm
Minimum Welded Belt Length	1.200 mm
Minimum Number of Pulley Teeth z_{\min}	28 (Steel/Aramid) 23 (HF)
Minimum Pulley Diameter	124.78 mm (Steel/Aramid) 102.5 mm (HF)
Minimum Back Bend Diameter	200 mm (Steel/Aramid) 160 mm (HF)
FDA/EU Approval	No

HTD®14

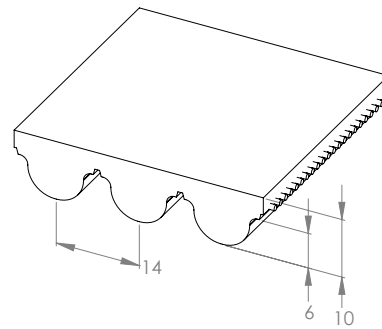

Standard Width (mm)	25	40	55	85	115	170
Tensile Strength (Average Value) F_{Break} (N)						
Steel	20 760	34 600	48 440	74 390	102 070	152 240
Aramid	18 995	31 327	43 658	68 321	92 984	138 199
HF	23 100	38 500	53 900	82 775	113 575	169 400
Allowable Belt Force F_{1all} (N) Open Ended						
Steel	5 156	8 593	12 031	18 476	25 350	37 811
Aramid	1 515	2 499	3 482	5 449	7 416	11 022
HF	4 470	7 449	10 429	16 016	21 975	32 776
Allowable Belt Force F_{1all} (N) Endless Welded						
Steel	2 578	4 297	6 015	9 238	12 675	18 905
Aramid	1 136	1 874	2 612	4 087	5 562	8 267
HF	2 235	3 725	5 214	8 008	10 988	16 388
Allowable Effective Force F_{eall} (N)						
(Minimum 15 teeth are in mesh)	3 430	5 488	7 546	11 662	15 778	23 324
Specific Belt Mass m_{sp} (kg/m/mm)						
Steel	0.0108					
Aramid	0.0084					
HF	0.0112					
Specific Belt Stiffness c_{sp} (N)						
Steel	1 289 000	2 148 333	3 007 667	4 618 917	6 337 583	9 452 667
Aramid	378 750	624 627	870 504	1 362 258	1 854 012	2 755 561
HF	1 117 380	1 862 300	2 607 220	4 003 945	5 493 785	8 194 120

TIMING BELTS

SELF TRACKING

FLAT BELTS

WIDE BELTS

ENDLESS BELTS

FINISHING

INFORMATION

LINEAR BELTS

METRIC TIMING BELTS

TIMING BELTS

SELF TRACKING

FLAT BELTS

WIDE BELTS

ENDLESS BELTS

FINISHING

INFORMATION

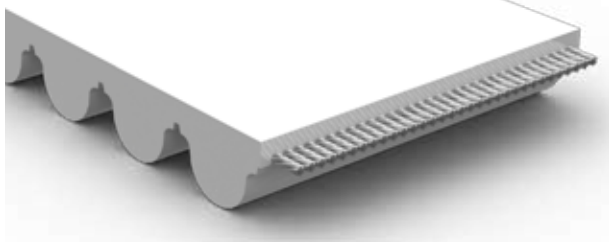

Pitch	14 mm
Standard Color	White
Standard Roll Length ($\pm 1\%$)	50 m
Width Tolerance	
up to 55 mm Width	± 1.0 mm
> 55 mm up to 100 mm Width	± 1.5 mm
> 100 mm Width	± 2.0 mm
Sitting Lanes	No Sitting Lanes
Minimum Welded Belt Length	No Welding
Minimum Number of Pulley Teeth z_{min}	36
Minimum Pulley Diameter	160.43 mm
Minimum Back Bend Diameter	200 mm
FDA/EU Approval	No

HTD® L14

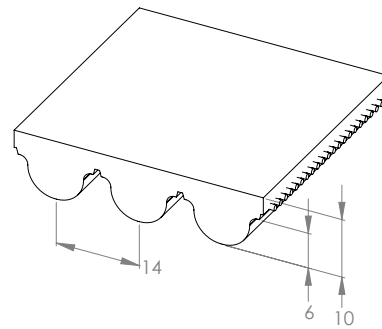

Standard Width (mm)	55	85	115	170
Tensile Strength (Average Value) F_{Break} (N)				
Steel	76 800	121 600	163 200	246 400
Allowable Belt Force F_{1all} (N) Open Ended				
Steel	16 811	26 617	35 723	53 935
Allowable Effective Force F_{eall} (N)				
(Minimum 15 teeth are in mesh)	7 546	11 662	15 778	23 324
Specific Belt Mass m_{sp} (kg/m/mm)				
Steel	0.0122			
Specific Belt Stiffness c_{sp} (N)				
Steel	4 202 727	6 654 318	8 930 795	13 483 750

TIMING BELTS

SELF TRACKING

FLAT BELTS

WIDE BELTS

ENDLESS BELTS

FINISHING

INFORMATION

LINEAR BELTS

METRIC TIMING BELTS

TIMING BELTS

SELF TRACKING

FLAT BELTS

WIDE BELTS

ENDLESS BELTS

FINISHING

INFORMATION



Pitch	5 mm
Standard Color	White
Standard Roll Length ($\pm 1\%$)	100 m
Width Tolerance	± 0.5 mm
Sitting Lanes Standard	25 mm
Optional	10 mm
Minimum Welded Belt Length	480 mm
Minimum Number of Pulley Teeth z_{min}	14
Minimum Pulley Diameter	22.28 mm
Minimum Back Bend Diameter	60 mm
FDA/EU Approval	No

STD5

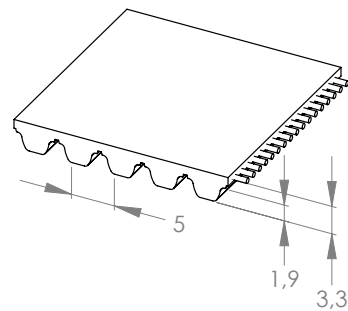

Standard Width (mm)	10	15	20	25	30	50
Tensile Strength (Average Value) F_{Break} (N)						
Steel	3 720	5 580	8 060	10 540	12 400	21 700
Aramid	2 911	4 635	6 360	8 085	9 810	16 709
Allowable Belt Force F_{1all} (N) Open Ended						
Steel	826	1 239	1 789	2 340	2 753	4 818
Aramid	383	610	837	1 064	1 290	2 198
Allowable Belt Force F_{1all} (N) Endless Welded						
Steel	413	619	895	1 170	1 376	2 409
Aramid	287	457	627	798	968	1 648
Allowable Effective Force F_{eall} (N)						
(Minimum 15 teeth are in mesh)	392	588	784	980	1 176	1 960
Specific Belt Mass m_{sp} (kg/m/mm)						
Steel	0.0038					
Aramid	0.0029					
Specific Belt Stiffness c_{sp} (N)						
Steel	206 471	309 706	447 353	585 000	688 235	1 204 412
Aramid	95 715	152 435	209 155	265 875	322 595	549 475

TIMING BELTS

SELF TRACKING

FLAT BELTS

WIDE BELTS

ENDLESS BELTS

FINISHING

INFORMATION

LINEAR BELTS

METRIC TIMING BELTS

TIMING BELTS

SELF-TRACKING

FLAT BELTS

WIDE BELTS

ENDLESS BELTS

FINISHING

INFORMATION

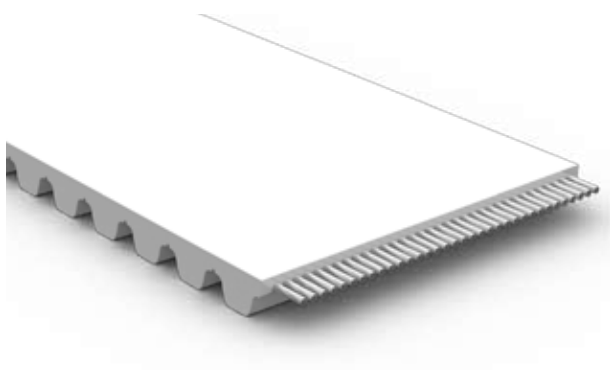

Pitch	8 mm
Standard Color	White
Standard Roll Length ($\pm 1\%$)	100 m
Width Tolerance	
up to 50 mm Width	± 0.75 mm
> 50 mm Width	± 1.0 mm
Sitting Lanes	
Standard	20 mm / 30 mm
Optional	25 mm
Minimum Welded Belt Length	960 mm
Minimum Number of Pulley Teeth z_{\min}	20 (Steel/Aramid) 25 (Niro) 16 (HF)
Minimum Pulley Diameter	50.93 mm (Steel/Aramid) 81.48 mm (Niro) 40.8 mm (HF)
Minimum Back Bend Diameter	120 mm (Steel/Aramid) 150 mm (Niro) 100 mm (HF)
FDA/EU Approval	No

STD8

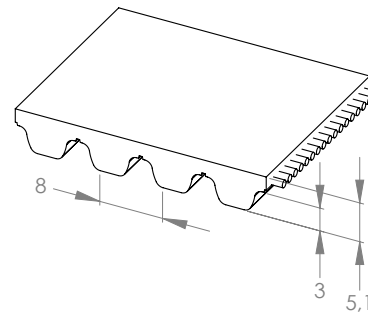

Standard Width (mm)	10	15	20	25	30	50	85	100	150
Tensile Strength (Average Value) F_{Break} (N)									
Steel	4 750	7 600	10 450	14 250	17 100	29 450	50 350	59 850	90 250
Aramid	5 827	9 279	12 732	16 185	19 638	33 449	57 619	67 977	102 505
Niro	3 563	5 700	7 838	10 688	12 825	22 088	37 763	44 888	67 688
HF	4 325	6 920	9 515	12 975	15 570	26 815	45 845	54 495	82 175
Allowable Belt Force F_{1all} (N) Open Ended									
Steel	1 247	1 995	2 743	3 741	4 489	7 731	13 218	15 712	23 693
Aramid	630	1 003	1 377	1 750	2 123	3 617	6 230	7 350	11 083
Niro	935	1 496	2 058	2 806	3 367	5 799	9 914	11 784	17 770
HF	1 152	1 843	2 534	3 456	4 147	7 142	12 211	14 515	21 888
Allowable Belt Force F_{1all} (N) Endless Welded									
Steel	624	998	1 372	1 871	2 245	3 866	6 609	7 856	11 847
Aramid	473	753	1 033	1 313	1 593	2 713	4 673	5 513	8 313
Niro	468	748	1 029	1 403	1 683	2 899	4 957	5 892	8 885
HF	576	922	1 267	1 728	2 074	3 571	6 106	7 258	10 944
Allowable Effective Force F_{eall} (N)									
(Minimum 15 teeth are in mesh)	728	1 092	1 456	1 820	2 184	3 640	6 188	7 280	10 920
Specific Belt Mass m_{sp} (kg/m/mm)									
Steel					0.0058				
Aramid					0.0043				
Niro					0.0057				
HF					0.0056				
Specific Belt Stiffness c_{sp} (N)									
Steel	311 750	498 800	685 850	935 250	1 122 300	1 923 850	3 304 550	3 928 050	5 923 250
Aramid	157 500	250 833	344 167	437 500	530 833	904 167	1 557 500	1 837 500	2 770 833
Niro	233 813	374 100	514 388	701 438	841 725	1 449 638	2 478 413	2 946 038	4 442 438
HF	288 000	460 800	633 600	864 000	1 036 800	1 785 600	3 052 800	3 628 800	5 472 000

TIMING BELTS

SELF TRACKING

FLAT BELTS

WIDE BELTS

ENDLESS BELTS

FINISHING

INFORMATION

LINEAR BELTS

METRIC TIMING BELTS

TIMING BELTS

SELF TRACKING

FLAT BELTS

WIDE BELTS

ENDLESS BELTS

FINISHING

INFORMATION

Feature:
very strong, long life

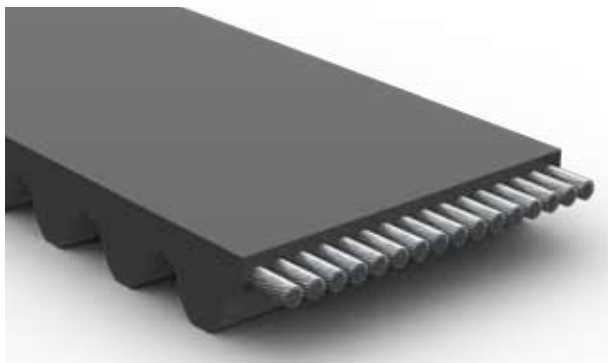

Pitch	14 mm
Standard Color	Black
Standard Roll Length ($\pm 1\%$)	50 m
Width Tolerance	
up to 55 mm Width	± 1.0 mm
> 55 mm Width	± 1.5 mm
> 100 mm Width	± 2.0 mm
Sitting Lanes	
Standard	85 mm
Optional	55 mm / 115 mm
Minimum Welded Belt Length	No Welding
Minimum Number of Pulley Teeth z_{min}	34
Minimum Pulley Diameter	151 mm
Minimum Back Bend Diameter	250 mm
FDA/EU Approval	No

HPL[®]14-RSL

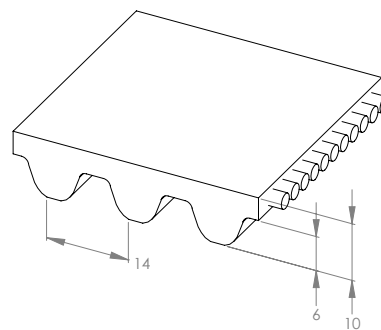

Standard Width (mm)	55	85	115	170
Tensile Strength (Average Value) F_{Break} (N)				
Steel	97 500	157 500	217 500	315 000
Allowable Belt Force F_{1all} (N) Open Ended				
Steel	23 189	37 459	51 729	74 918
Allowable Effective Force F_{eall} (N)				
(Minimum 15 teeth are in mesh)	8 305	12 835	17 365	25 670
Specific Belt Mass m_{sp} (kg/m/mm)				
Steel	0.014	0.014	0.013	0.012
Specific Belt Stiffness c_{sp} (N)				
Steel	5 797 187	9 364 687	12 932 187	18 729 375

TIMING BELTS

SELF TRACKING

FLAT BELTS

WIDE BELTS

ENDLESS BELTS

FINISHING

INFORMATION

LINEAR BELTS

METRIC TIMING BELTS

TIMING BELTS

SELF TRACKING

FLAT BELTS

WIDE BELTS

ENDLESS BELTS

FINISHING

INFORMATION

Feature:
antistatic, corresponds to:
IEC DTS 60079- 32, TRBS 2153, CENELEC TR50404



Pitch	5 mm
Standarddicke	2.6 mm
Standard Color	White
Standard Roll Length ($\pm 1\%$)	100 m
Width Tolerance up to 50 mm Width > 50 mm Width	± 0.5 mm ± 0.75 mm
Sitting Lanes Standard Optional	25 mm 10 mm / 16 mm
Minimum Welded Belt Length	480 mm
Minimum Number of Pulley Teeth z_{min}	10
Minimum Pulley Diameter	15.91 mm
Minimum Back Bend Diameter	30 mm
FDA/EU Approval	No
Polyurethane	R1 / 92 Shore A
Backing	Antistatic Polyamide Fabric on Tooth and Back

T5-ATB

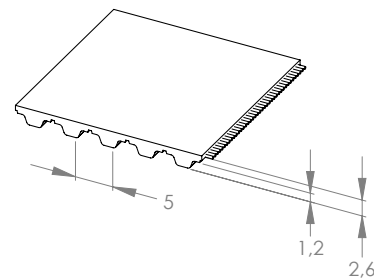

Standard Width (mm)	10	16	25	32	50	75	100
Tensile Strength (Average Value) F_{Break} (N)							
Steel	1 250	2 000	3 375	4 250	6 875	10 375	13 875
Allowable Belt Force F_{1all} (N) Open Ended							
Steel	311	498	840	1 058	1 711	2 582	3 453
Allowable Belt Force F_{1all} (N) Endless Welded							
Steel	156	249	420	529	856	1 291	1 727
Allowable Effective Force F_{eall} (N)							
(Minimum 15 teeth are in mesh)	356	570	890	1 139	1 780	2 670	3 560
Specific Belt Mass m_{sp} (kg/m/mm)							
Steel	0.0022						
Specific Belt Stiffness c_{sp} (N)							
Steel	77 778	124 444	210 000	264 444	427 778	645 556	863 333

TIMING BELTS

SELF TRACKING

FLAT BELTS

WIDE BELTS

ENDLESS BELTS

FINISHING

INFORMATION

LINEAR BELTS

METRIC TIMING BELTS

TIMING BELTS

SELF TRACKING

FLAT BELTS

WIDE BELTS

ENDLESS BELTS

FINISHING

INFORMATION

Features:
completely sealed, no flights

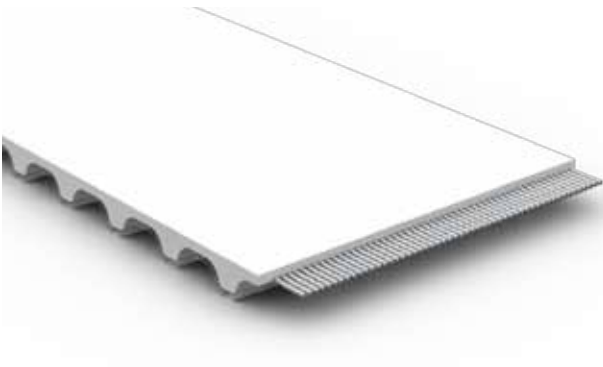

Pitch	10 mm
Standard Color	White
Standard Roll Length ($\pm 1\%$)	100 m
Width Tolerance	
up to 50 mm Width	± 0.5 mm
> 50 mm Width	± 0.75 mm
Sitting Lanes	
Standard	25 mm
Optional	10 mm / 16 mm
Minimum Welded Belt Length	No Welding
Minimum Number of Pulley Teeth z_{min}	14 (Steel/Aramid) 12 (HF)
Minimum Pulley Diameter	44.56 mm (Steel/Aramid) 38.20 mm (HF)
Minimum Back Bend Diameter	80 mm (Steel/Aramid) 60 mm (HF)
FDA/EU Approval	No

WR10

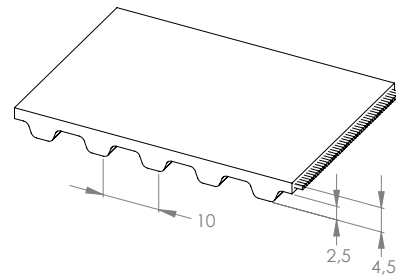

Standard Width (mm)	12	16	25	32	40	50	75	100	150
Tensile Strength (Average Value) F_{Break} (N)									
Steel	2 940	4 200	7 140	9 240	11 340	14 700	22 260	29 820	44 940
Aramid	3 601	4 980	8 085	10 500	13 259	16 709	25 333	33 957	51 205
HF	4 340	6 200	10 540	13 640	16 740	21 700	32 860	44 020	66 340
Allowable Belt Force F_{1all} (N) Open Ended									
Steel	786	1 123	1 909	2 470	3 031	3 929	5 950	7 971	12 012
Aramid	474	655	1 064	1 381	1 744	2 198	3 332	4 467	6 736
HF	964	1 376	2 340	3 028	3 716	4 818	7 295	9 773	14 728
Allowable Effective Force F_{eall} (N)									
(Minimum 15 teeth are in mesh)	811	1 082	1 690	2 163	2 704	3 380	5 070	6 760	10 140
Specific Belt Mass m_{sp} (kg/m/mm)									
Steel	0.0044								
Aramid	0.0036								
HF	0.0047								
Specific Belt Stiffness c_{sp} (N)									
Steel	196 463	280 662	477 125	617 456	757 787	982 316	1 487 507	1 992 699	3 003 081
Aramid	118 403	163 779	265 875	345 283	436 035	549 475	833 075	1 116 675	1 683 875
HF	240 882	344 118	585 000	757 059	929 118	1 204 412	1 823 824	2 443 235	3 682 059

TIMING BELTS

SELF TRACKING

FLAT BELTS

WIDE BELTS

ENDLESS BELTS

FINISHING

INFORMATION

LINEAR BELTS

IMPERIAL TIMING BELTS

TIMING BELTS

SELF-TRACKING

FLAT BELTS

WIDE BELTS

ENDLESS BELTS

FINISHING

INFORMATION



Pitch	0.200" / 5.08 mm
Standard Color	White
Standard Roll Length ($\pm 1\%$)	327.8 feet / 100 m
Width Tolerance*	
up to 2" Width	$\pm 0.020"$ / 0.51 mm
> 2" Width (nur Steel)	$\pm 0.030"$ / 0.76 mm
Sitting Lanes	
Standard	0.25" / 6.35 mm
Optional	1" / 25.4 mm
Minimum Welded Belt Length	19.2" / 487.68 mm
Minimum Number of Pulley Teeth z_{min}	10
Minimum Pulley Diameter	0.64" / 16.25 mm
Minimum Back Bend Diameter	1.125" / 28.6 mm
FDA-Approval	Yes (Aramid Cord)

* With aramid cord only up to 2" width available.

XL

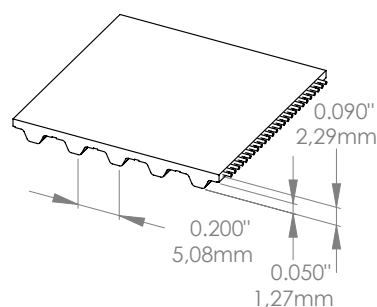

Standard Width (Inch)	0.25	0.31	0.37	0.50	0.75	1	2	4
Tensile Strength (Average Value) F_{Break} (N)								
Steel	750	875	1 125	1 625	2 500	3 375	6 875	13 875
Aramid	976	1 238	1 525	2 074	3 172	4 270	8 662	----*
Allowable Belt Force F_{1all} (N) Open Ended								
Steel	190	221	284	411	632	853	1 738	3 509
Aramid	213	270	332	452	691	930	1 887	----*
Allowable Belt Force F_{1all} (N) Endless Welded								
Steel	95	111	142	205	316	427	869	1 754
Aramid	159	202	249	339	518	698	1 415	----*
Allowable Effective Force F_{eall} (N)								
	200	248	300	400	600	800	1 600	3 200
Specific Belt Mass m_{sp} (kg/m/mm)								
Steel	0.0022							
Aramid	0.0019							
Specific Belt Stiffness c_{sp} (N)								
Steel	47 413	55 316	71 120	102 729	158 044	213 360	434 622	877 147
Aramid	51 675	66 058	81 819	111 962	172 250	232 537	473 686	----*

TIMING BELTS

SELF TRACKING

FLAT BELTS

WIDE BELTS

ENDLESS BELTS

FINISHING

INFORMATION

LINEAR BELTS

IMPERIAL TIMING BELTS

TIMING BELTS

SELF-TRACKING

FLAT BELTS

WIDE BELTS

ENDLESS BELTS

FINISHING

INFORMATION



Pitch	0.375" / 9.525 mm
Standard Color	White
Standard Roll Length ($\pm 1\%$)	200 feet / 61 m
Width Tolerance up to 2" Width	$\pm 0.020"$ / 0.51 mm
> 2" Width	$\pm 0.030"$ / 0.76 mm
Sitting Lanes Standard	0.25" / 6.35 mm
Optional	0.50" / 12.7 mm
Minimum Welded Belt Length	19.125" / 485.78 mm
Minimum Number of Pulley Teeth z_{min}	10
Minimum Pulley Diameter	1.19" / 30.25 mm
Minimum Back Bend Diameter	2.375" / 60.3 mm
FDA-Approval	Yes (Aramid Cord)

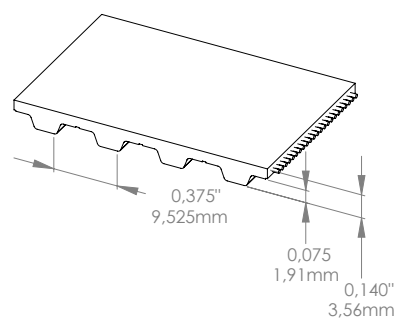

Standard Width (Inch)	0.37	0.50	0.75	1	1.5	2	4
Tensile Strength (Average Value) F_{Break} (N)							
Steel	2 280	3 135	4 845	6 555	9 975	13 395	27 075
Aramid	2 672	3 674	5 678	7 682	11 690	15 698	31 730
Allowable Belt Force F_{1all} (N) Open Ended							
Steel	574	790	1 221	1 652	2 513	3 375	6 821
Aramid	428	588	909	1 229	1 871	2 512	5 078
Allowable Belt Force F_{1all} (N) Endless Welded							
Steel	287	395	610	826	1 257	1 687	3 411
Aramid	321	441	681	922	1 403	1 884	3 808
Allowable Effective Force F_{eall} (N)							
	600	800	1 200	1 600	2 400	3 200	6 400
Specific Belt Mass m_{sp} (kg/m/mm)							
Steel	0.0035						
Aramid	0.0030						
Specific Belt Stiffness c_{sp} (N)							
Steel	143 609	197 463	305 170	412 877	628 291	843 705	1 705 362
Aramid	106 901	146 989	227 164	307 340	467 691	628 043	1 269 448

TIMING BELTS

SELF TRACKING

FLAT BELTS

WIDE BELTS

ENDLESS BELTS

FINISHING

INFORMATION

LINEAR BELTS

IMPERIAL TIMING BELTS

TIMING BELTS

SELF-TRACKING

FLAT BELTS

WIDE BELTS

ENDLESS BELTS

FINISHING

INFORMATION



Pitch	0.500" / 12.7 mm
Standard Color	White
Standard Roll Length ($\pm 1\%$)	327.8 feet / 100 m
Width Tolerance up to 2" Width > 2" Width	$\pm 0.020"$ / 0.51 mm $\pm 0.030"$ / 0.76 mm
Sitting Lanes	1" / 25.4 mm
Minimum Welded Belt Length up to 4" Width > 4" Width	19" / 482.6 mm 38" / 965.2 mm
Minimum Number of Pulley Teeth z_{min}	14 (Steel/Aramid) 12 (HF)
Minimum Pulley Diameter	2.23" / 56.65 mm (Steel/Aramid) 1.91" / 48.5 mm (HF)
Minimum Back Bend Diameter	3.125" / 79.4 mm (Steel/Aramid) 2.375" / 60.3 mm (HF)
FDA-Approval	Yes (Aramid Cord)

H

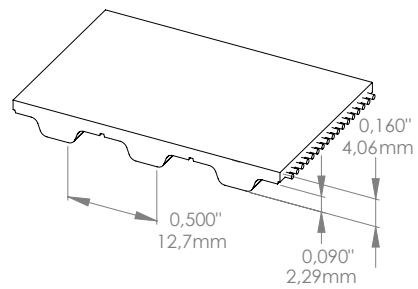

Standard Width (Inch)	0.50	0.75	1	1.5	2	3	4	6
Tensile Strength (Average Value) F_{Break} (N)								
Steel	3 360	5 040	7 140	10 920	14 700	22 260	29 820	44 940
Aramid	3 773	5 929	8 085	12 397	16 709	25 333	33 957	51 205
HF	4 960	7 440	10 540	16 120	21 700	32 860	44 020	66 340
Allowable Belt Force F_{1all} (N) Offe								
Steel	912	1 369	1 939	2 966	3 992	6 045	8 098	12 205
Aramid	504	792	1 081	1 657	2 233	3 386	4 538	6 843
HF	1 119	1 678	2 377	3 636	4 895	7 412	9 929	14 964
Allowable Belt Force F_{1all} (N) Endless Welded								
Steel	456	684	970	1 483	1 996	3 023	4 049	6 102
Aramid	378	594	810	1 243	1 675	2 539	3 404	5 132
HF	559	839	1 189	1 818	2 447	3 706	4 965	7 482
Allowable Effective Force F_{eall} (N)								
(Minimum 15 teeth are in mesh)	980	1 470	1 960	2 940	3 920	5 880	7 840	11 760
Specific Belt Mass m_{sp} (kg/m/mm)								
Steel	0.0040							
Aramid	0.0032							
HF	0.0043							
Specific Belt Stiffness c_{sp} (N)								
Steel	228 122	342 183	484 759	741 396	998 033	1 511 307	2 024 582	3 051 130
Aramid	126 060	198 095	270 129	414 198	558 267	846 404	1 134 542	1 710 817
HF	279 699	419 548	594 360	909 021	1 223 682	1 853 005	2 482 327	3 740 972

TIMING BELTS

SELF TRACKING

FLAT BELTS

WIDE BELTS

ENDLESS BELTS

FINISHING

INFORMATION

LINEAR BELTS

IMPERIAL TIMING BELTS

TIMING BELTS

SELF-TRACKING

FLAT BELTS

WIDE BELTS

ENDLESS BELTS

FINISHING

INFORMATION

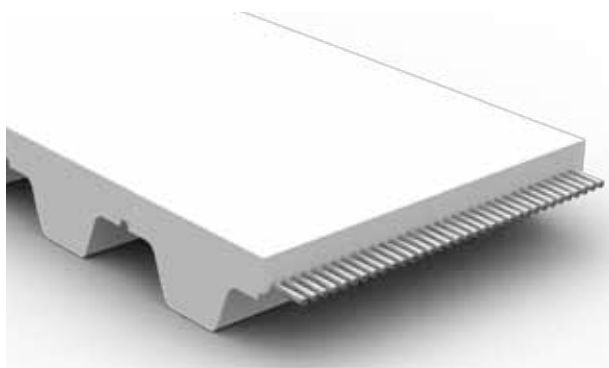

Pitch	0.875" / 22.225 mm
Standard Color	White
Standard Roll Length ($\pm 1\%$)	200 feet / 61 m
Width Tolerance	$\pm 0.040"$ / 1.02 mm
Sitting Lanes	1" / 25.4 mm
Minimum Welded Belt Length up to 4" Width > 4" Width	39.4" / 1 000.76 mm No Welding
Minimum Number of Pulley Teeth z_{\min}	18
Minimum Pulley Diameter	5.01" / 127.75 mm
Minimum Back Bend Diameter	5.875" / 149.2 mm
FDA-Approval	No

XH

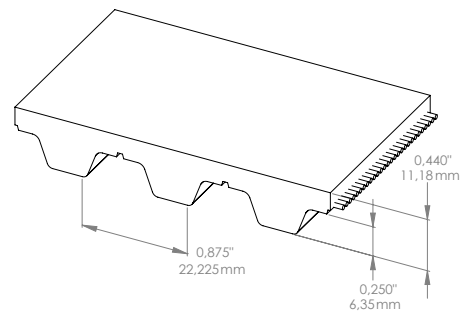

Standard Width (Inch)	1	1.5	2	3	4	6
Tensile Strength (Average Value) F_{Break} (N)						
Steel	14 250	21 850	29 450	44 650	59 850	90 250
Aramid	16 185	24 817	33 449	50 713	67 977	102 505
Allowable Belt Force F_{1all} (N) Offe						
Steel	3 801	5 828	7 855	11 909	15 964	24 072
Aramid	1 778	2 726	3 675	5 571	7 468	11 261
Allowable Belt Force F_{1all} (N) Endless Welded						
Steel	1 900	2 914	3 928	5 955	7 982	--- *
Aramid	1 334	2 045	2 756	4 178	5 601	--- *
Allowable Effective Force F_{eall} (N)						
(Minimum 15 teeth are in mesh)	3 910	5 865	7 820	11 730	15 640	23 460
Specific Belt Mass m_{sp} (kg/m/mm)						
Steel	0.0106					
Aramid	0.0091					
Specific Belt Stiffness c_{sp} (N)						
Steel	950 214	1 456 995	1 963 776	2 977 337	3 990 899	6 018 022
Aramid	444 500	681 567	918 633	1 392 767	1 866 900	2 815 167

*Welding only up to 4" width available

TIMING BELTS

SELF TRACKING

FLAT BELTS

WIDE BELTS

ENDLESS BELTS

FINISHING

INFORMATION

LINEAR BELTS

SELF TRACKING BELTS





Gates Self Tracking Belts are a composed construction of Gates' standard polyurethane belts and specially designed polyurethane V-Guides, which provide highest flexibility and allow the use of small pulley diameters. Self tracking belts can be manufactured in two different production processes:

- › Fabricated V-Guides can be combined with any belt type and belt width.
- › Integral V-Guides are integrated by co-extrusion in the belt producing process and ensure higher strength and consistency.

ATTRIBUTES

- › V-Guides can be added to nearly every belt type.
- › Synchronous operations
- › Operation without flanged pulleys possible
- › Reliable tracking which is not affected by lateral forces
- › Reduction of lateral movement

APPLICATIONS

- › Long length conveying
- › Industrial handling
- › General conveying
- › Linear / rotary positioning

PROCESSING OPTIONS

- › Backings *Further information on page 124*
- › Profiles *Further information on page 138*
- › Special processing *Further information on page 146*

LINEAR BELTS

FARICATED V-GUIDES

TIMING BELTS

SELF-TRACKING

FLAT BELTS

WIDE BELTS

ENDLESS BELTS

FINISHING

INFORMATION

FOR METRIC TOOTH PITCH BELTS

K6- Section

K10- Section

K13- Section

BELT DIMENSIONS

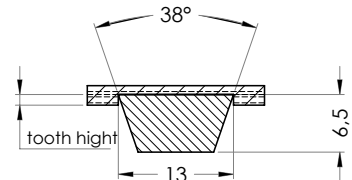
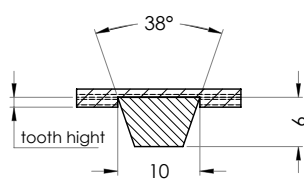
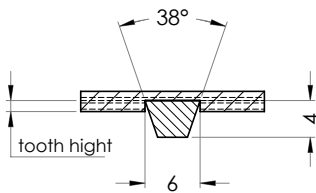

PULLEY DIMENSIONS

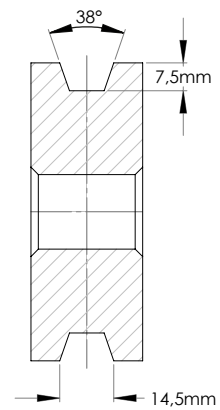
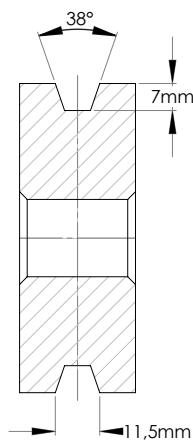
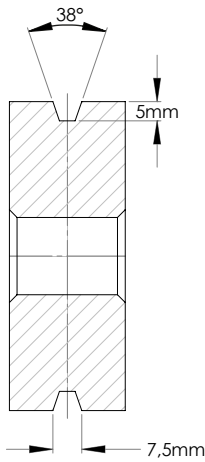

SLIDER BED DIMENSIONS

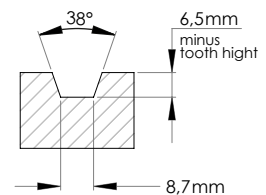
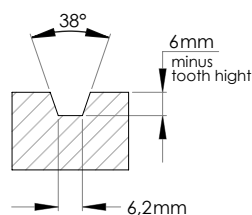
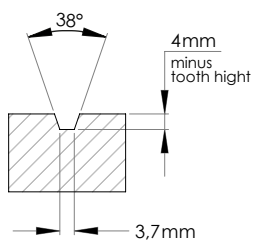

FOR IMPERIAL TOOTH PITCH BELTS

A-Section

O-Section

BELT DIMENSIONS

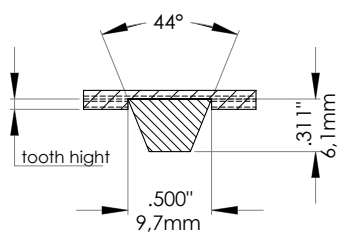
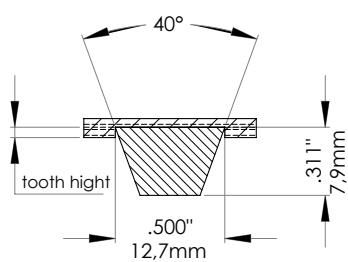

PULLEY DIMENSIONS

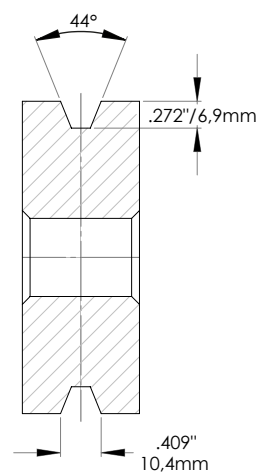
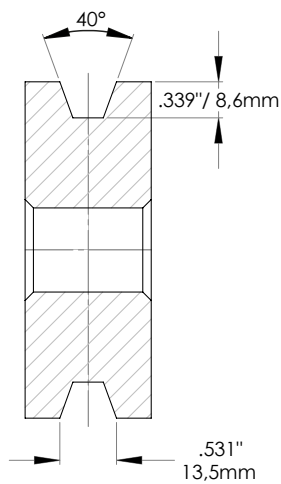

SLIDER BED DIMENSIONS

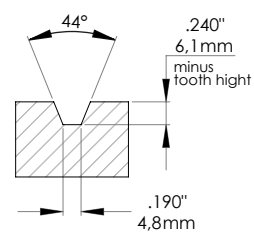
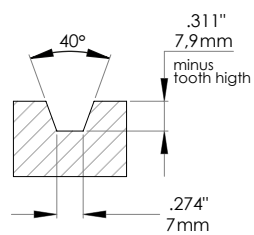

LINEAR BELTS

INTEGRAL V-GUIDE

TIMING BELTS

SELF-TRACKING

FLAT BELTS

WIDE BELTS

ENDLESS BELTS

FINISHING

INFORMATION



Pitch	5 mm
Integral V-Guide	K6
Standard Color	White
Standard Roll Length ($\pm 1\%$)	100 m
Width Tolerance up to 50 mm Width	± 0.5 mm
> 50 mm Width	± 0.75 mm
Sitting Lanes	25 mm
Minimum Welded Belt Length	960 mm
Minimum Number of Pulley Teeth z_{\min}	10
Minimum Pulley Diameter	15.91 mm
Minimum Back Bend Diameter	30 mm
FDA/EU Approval	No

T5V

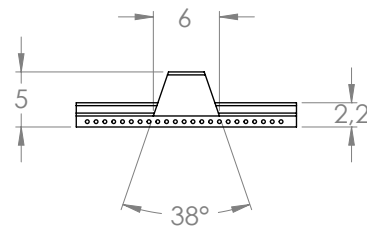

Standard Width (mm)	25	32	50	100
Tensile Strength (Average Value) F_{Break} (N)				
Steel	3 375	4 250	6 875	13 875
Aramid	8 370	10 800	17 050	34 410
Allowable Belt Force F_{1all} (N) Open Ended				
Steel	840	1 058	1 711	3 453
Aramid	916	1 181	1 865	3 764
Allowable Belt Force F_{1all} (N) Endless Welded				
Steel	420	529	856	1 727
Aramid	687	886	1 399	2 823
Allowable Effective Force F_{eall} (N)				
(Minimum 15 teeth are in mesh)	676	926	1 566	3 346
Specific Belt Mass m_{sp} (kg/m)				
Steel	0.07	0.09	0.13	0.24
Aramid	0.07	0.08	0.12	0.22
Specific Belt Stiffness c_{sp} (N)				
Steel	210 000	264 444	427 778	863 333
Aramid	228 875	295 334	466 227	940 931

TIMING BELTS

SELF TRACKING

FLAT BELTS

WIDE BELTS

ENDLESS BELTS

FINISHING

INFORMATION

LINEAR BELTS

INTEGRAL V-GUIDE

TIMING BELTS

SELF-TRACKING

FLAT BELTS

WIDE BELTS

ENDLESS BELTS

FINISHING

INFORMATION

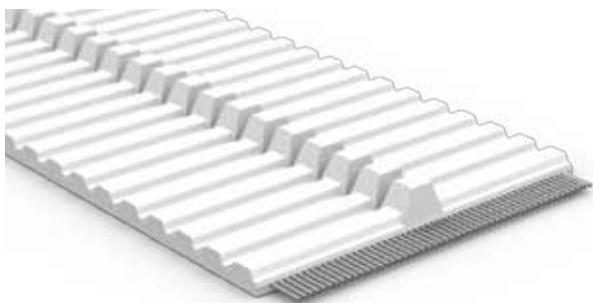

Pitch	5 mm
Integral V-Guide	K6
Standard Color	White
Standard Roll Length ($\pm 1\%$)	100 m
Width Tolerance	± 0.5 mm
Sitting Lanes	25 mm
Minimum Welded Belt Length	960 mm
Minimum Number of Pulley Teeth z_{\min}	15
Minimum Pulley Diameter	23.87 mm
Minimum Back Bend Diameter	60 mm
FDA/EU Approval	No

AT5V

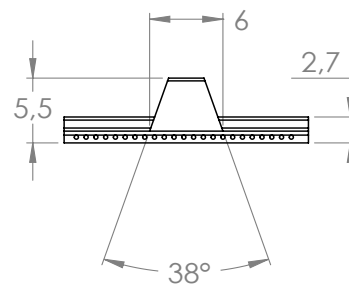

Standard Width (mm)	25	50
Tensile Strength (Average Value) F_{Break} (N)		
Steel	7 125	14 535
Aramid	8 350	17 034
Allowable Belt Force F_{1all} (N) Open Ended		
Steel	1 761	3 591
Aramid	1 210	2 468
Allowable Belt Force F_{1all} (N) Open Ended		
Steel	880	1 796
Aramid	908	1 851
Allowable Effective Force F_{eall} (N)		
(Minimum 15 teeth are in mesh)	980	2 270
Specific Belt Mass m_{sp} (kg/m)		
Steel	0.10	0.19
Aramid	0.09	0.15
Specific Belt Stiffness c_{sp} (N)		
Steel	440 125	897 855
Aramid	302 500	617 100

TIMING BELTS

SELF TRACKING

FLAT BELTS

WIDE BELTS

ENDLESS BELTS

FINISHING

INFORMATION

LINEAR BELTS

INTEGRAL V-GUIDE

TIMING BELTS

SELF-TRACKING

FLAT BELTS

WIDE BELTS

ENDLESS BELTS

FINISHING

INFORMATION

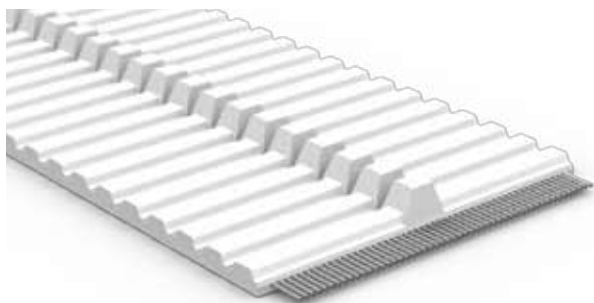

Pitch	5 mm
Integral V-Guide	K6
Standard Color	White
Standard Roll Length ($\pm 1\%$)	100 m
Width Tolerance	± 0.5 mm
Sitting Lanes	25 mm
Minimum Welded Belt Length	No Welding
Minimum Number of Pulley Teeth z_{\min}	15
Minimum Pulley Diameter	23.87 mm
Minimum Back Bend Diameter	60 mm
FDA/EU Approval	No

ATL5V

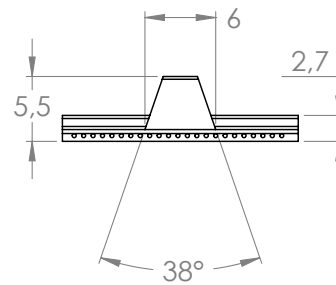

Standard Width (mm)	25	50
Tensile Strength (Average Value) F_{Break} (N)		
Steel	10 540	21 700
Allowable Belt Force F_{1all} (N) Open Ended		
Steel	2 340	4 818
Allowable Effective Force F_{eall} (N) (Minimum 15 teeth are in mesh)		
	980	2 270
Specific Belt Mass m_{sp} (kg/m)		
Steel	0.09	0.16
Specific Belt Stiffness c_{sp} (N)		
Steel	585 000	1 204 412

TIMING BELTS

SELF TRACKING

FLAT BELTS

WIDE BELTS

ENDLESS BELTS

FINISHING

INFORMATION

LINEAR BELTS

INTEGRAL V-GUIDE

TIMING BELTS

SELF-TRACKING

FLAT BELTS

WIDE BELTS

ENDLESS BELTS

FINISHING

INFORMATION

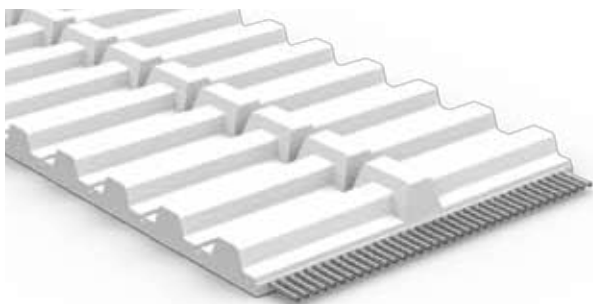

Pitch	10 mm
Integral V-Guide	K6
Standard Color	White
Standard Roll Length ($\pm 1\%$)	100 m
Width Tolerance	± 0.5 mm
Sitting Lanes	25 mm
Minimum Welded Belt Length	960 mm
Minimum Number of Pulley Teeth z_{\min}	14
Minimum Pulley Diameter	44.56 mm
Minimum Back Bend Diameter	80 mm
FDA/EU Approval	No

T10VS

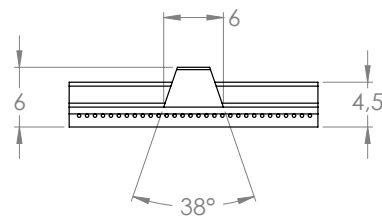

Standard Width (mm)	25	32	50
Tensile Strength (Average Value) F_{Break} (N)			
Steel	7 140	9 240	14 700
Aramid	9 163	11 880	18 865
Allowable Belt Force F_{1all} (N) Open Ended			
Steel	1 909	2 470	3 929
Aramid	1 064	1 379	2 190
Allowable Belt Force F_{1all} (N) Endless Welded			
Steel	954	1 235	1 965
Aramid	798	1 034	1 642
Allowable Effective Force F_{eall} (N)			
(Minimum 15 teeth are in mesh)	1 284	1 758	2 974
Specific Belt Mass m_{sp} (kg/m)			
Steel	0.13	0.16	0.24
Aramid	0.11	0.13	0.20
Specific Belt Stiffness c_{sp} (N)			
Steel	477 125	617 456	982 316
Aramid	265 875	344 699	547 390

TIMING BELTS

SELF TRACKING

FLAT BELTS

WIDE BELTS

ENDLESS BELTS

FINISHING

INFORMATION

LINEAR BELTS

INTEGRAL V-GUIDE

TIMING BELTS

SELF-TRACKING

FLAT BELTS

WIDE BELTS

ENDLESS BELTS

FINISHING

INFORMATION

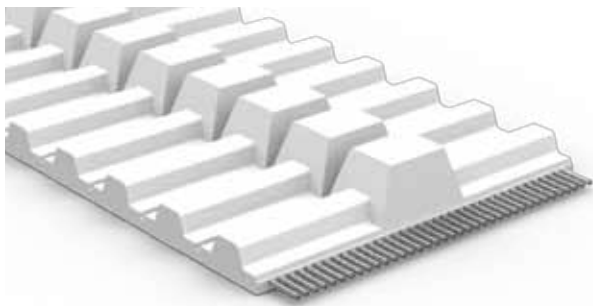

Pitch	10 mm
Integral V-Guide	K13
Standard Color	White
Standard Roll Length ($\pm 1\%$)	100 m
Width Tolerance up to 50 mm Width	± 0.5 mm
> 50 mm Width	± 0.75 mm
Sitting Lanes	25 mm
Minimum Welded Belt Length	960 mm
Minimum Number of Pulley Teeth z_{\min}	14
Minimum Pulley Diameter	44.56 mm
Minimum Back Bend Diameter	80 mm
FDA/EU Approval	No

T10V

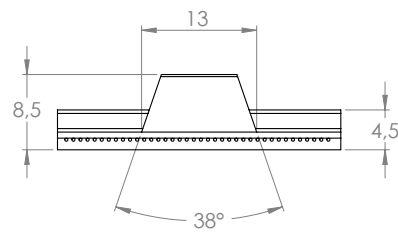

Standard Width (mm)	25	32	50	75	100	150
Tensile Strength (Average Value) F_{Break} (N)						
Steel	7 140	9 240	14 700	22 260	29 820	44 940
Aramid	9 163	11 880	18 865	28 567	38 269	57 673
Allowable Belt Force F_{1all} (N) Open Ended						
Steel	1 909	2 470	3 929	5 950	7 971	12 012
Aramid	1 064	1 379	2 190	3 316	4 442	6 694
Allowable Belt Force F_{1all} (N) Endless Welded						
Steel	954	1 235	1 965	2 975	3 985	6 006
Aramid	798	1 0324	1 642	2 487	3 331	5 020
Allowable Effective Force F_{eall} (N)						
(Minimum 15 teeth are in mesh)	811	1 284	2 501	4 191	5 881	9 261
Specific Belt Mass m_{sp} (kg/m)						
Steel	0.18	0.21	0.29	0.40	0.50	0.72
Aramid	0.16	0.18	0.25	0.34	0.43	0.61
Specific Belt Stiffness c_{sp} (N)						
Steel	477 125	617 456	982 316	1 487 507	1 992 699	3 003 081
Aramid	265 875	344 699	547 390	828 904	1 110 419	1 673 449

TIMING BELTS

SELF TRACKING

FLAT BELTS

WIDE BELTS

ENDLESS BELTS

FINISHING

INFORMATION

LINEAR BELTS

INTEGRAL V-GUIDE

TIMING BELTS

SELF-TRACKING

FLAT BELTS

WIDE BELTS

ENDLESS BELTS

FINISHING

INFORMATION

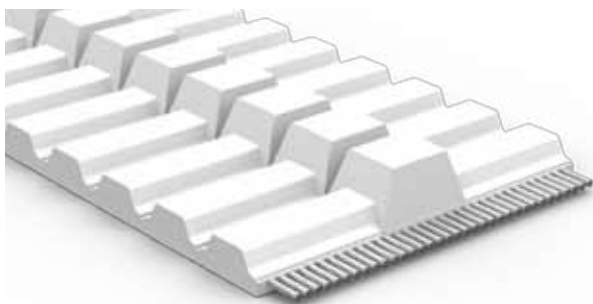

Pitch	10 mm
Integral V-Guide	K13
Standard Color	White
Standard Roll Length ($\pm 1\%$)	100 m
Width Tolerance	
up to 50 mm Width	± 0.75 mm
> 50 mm Width	± 1.0 mm
Sitting Lanes	25 mm
Minimum Welded Belt Length	960 mm
Minimum Number of Pulley Teeth z_{\min}	15 (Steel/Aramid) 12 (HF) 20 (Niro)
Minimum Pulley Diameter	47.75 mm (Steel/Aramid) 39 mm (HF) 63.7 mm (Niro)
Minimum Back Bend Diameter	120 mm (Steel/Aramid) 100 mm (HF) 160 mm (Niro)
FDA/EU Approval	No

AT10V

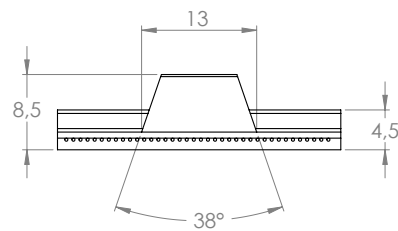

Standard Width (mm)	25	32	50	75
Tensile Strength (Average Value) F_{Break} (N)				
Steel	14 250	18 050	29 450	44 650
Aramid	16 185	21 019	33 449	50 713
HF	12 975	16 435	26 815	40 655
Niro	10 688	13 538	22 088	33 488
Allowable Belt Force F_{1all} (N) Open Ended				
Steel	3 741	4 739	7 731	11 722
Aramid	1 750	2 273	3 617	5 483
HF	3 456	4 378	7 142	10 829
Niro	2 806	3 554	5 799	8 791
Allowable Belt Force F_{1all} (N) Endless Welded				
Steel	1 871	2 369	3 866	5 861
Aramid	1 313	1 705	2 713	4 113
HF	1 728	2 189	3 571	5 414
Niro	1 403	1 777	2 899	4 396
Allowable Effective Force F_{eall} (N)				
(Minimum 15 teeth are in mesh)	1 238	1 961	3 818	6 398
Specific Belt Mass m_{sp} (kg/m)				
Steel	0.21	0.25	0.35	0.50
Aramid	0.17	0.20	0.28	0.38
HF	0.21	0.24	0.34	0.48
Niro	0.21	0.25	0.35	0.49
Specific Belt Stiffness c_{sp} (N)				
Steel	935 250	1 184 650	1 932 850	2 930 450
Aramid	437 500	568 167	904 167	1 370 833
HF	864 000	1 094 400	1 785 600	2 707 200
Niro	701 438	888 488	1 449 639	2 197 839

LINEAR BELTS

INTEGRAL V-GUIDE

TIMING BELTS

SELF-TRACKING

FLAT BELTS

WIDE BELTS

ENDLESS BELTS

FINISHING

INFORMATION

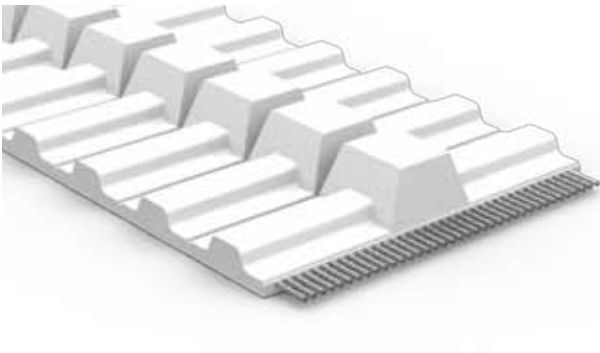

Pitch	0.500" / 12.7 mm
Integral V-Guide	A-Section
Standard Color	White
Standard Roll Length ($\pm 1\%$)	200 feet / 61 m
Width Tolerance up to 50 mm Width	$\pm 0.020"$ / 0.51 mm
> 50 mm Width	$\pm 0.030"$ / 0.76 mm
Sitting Lanes	1" / 25.4 mm
Minimum Welded Belt Length	36" / 914.4 mm
Minimum Number of Pulley Teeth z_{min}	14
Minimum Pulley Diameter	2.23" / 56.65 mm
Minimum Back Bend Diameter	3.125" / 79.4 mm
FDA/EU Approval	No

HV

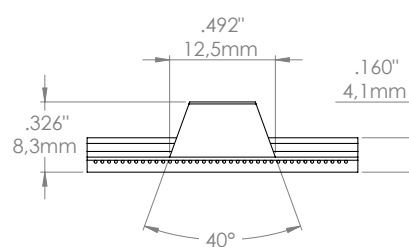

Standard Width (inch)	2	3	4	6
Tensile Strength (Average Value) F_{Break} (N)				
Steel	14 700	22 260	29 820	44 940
Aramid	18 865	28 567	38 269	57 673
Allowable Belt Force F_{1all} (N) Open Ended				
Steel	3 929	5 950	7 971	12 012
Aramid	2 127	3 221	4 315	6 503
Allowable Belt Force F_{1all} (N) Endless Welded				
Steel	1 965	2 975	3 985	6 006
Aramid	1 595	2 416	3 236	4 877
Allowable Effective Force F_{eall} (N)				
(Minimum 15 teeth are in mesh)	2 955	4 915	6 875	10 795
Specific Belt Mass m_{sp} (kg/m)				
Steel	0.27	0.37	0.47	0.67
Aramid	0.23	0.31	0.39	0.56
Specific Belt Stiffness c_{sp} (N)				
Steel	982 316	1 487 507	1 992 699	3 003 081
Aramid	531 750	805 221	1 078 693	1 625 636

TIMING BELTS

SELF TRACKING

FLAT BELTS

WIDE BELTS

ENDLESS BELTS

FINISHING

INFORMATION

LINEAR BELTS

FLAT BELTS BLACK-FLAT

TIMING BELTS

SELF TRACKING

FLAT BELTS

WIDE BELTS

ENDLESS BELTS

FINISHING

INFORMATIONEN

GATES BLACK-FLAT — Our Polyurethane Flat Belts are available in various constructions

Gates BLACK-FLAT belts are extruded flat belts made out of high strength Polyurethane. Commonly they are used in lifting and conveying applications. Our BLACK-FLAT belts are typically sold as open ended belts. Usually they are attached at one or both ends in the application with clamping plates or our new FIX-FLAT.

Our flat belts are adapted to a wide range of mechanical requirements. With combinations of different types of polyurethanes and cords we offer a wide variety of belts.

We also have a range of belts specially designed for applications in the food processing industry. These belts have FDA and EU approval.

Our latest development FIX-FLAT, the flat belt clamp, enables the secure clamping of any flat belts at both ends easily, quickly and safely. Patent applied for.

FEATURES

- › Smooth, vibration free operation
- › High strength combined with low elongation
- › Sealed belt edges result in no cord fraying
- › Easy belt guide with flanged pulleys or guiding rails
- › No re-tensioning required

TYPICAL APPLICATIONS:

- › Heavy load lifting or lowering
- › Exercise machines
- › Conveying applications
- › Applications with small pulley diameters

PROCESSING OPTIONS:

- › Backings *Further information on page 124*
- › Profiles *Further information on page 138*
- › Special processing *Further information on page 146*

CLAMP CONNECTION

- › Clamp FIX-FLAT *Further information on page 84*

FLAT BELTS BACK-FLAT	FABRIC BACKING					POLYURETHANE					Page	
	ECO Fabric	NT-Polyamide Fabric Tooth Side	NB-Polyamide Fabric Back	NTB-Polyamide Fabric Both Sides	ATB-Antistatic Fabric	R1-92 Shore A	R2-85 Shore A	R4-94 Shore A / Antistatic	EU F85-85 Shore A / EU Approval	EU F92-92 Shore A / EU Approval		FDA Approval
BFL20												
BFL20	●	●	●	●	●	●	●	●	●	●	●	76
BFL20-Aramid	●	●	●	●	●	●	●	●	●	●	●	76
BFL20-HF	●	●	●	●	●	●	●	●	●	●	●	77
BFL20-RSL	●	●	●	●	●	●	●	●	●	●	●	77
BFL20-RKV	●	●	●	●	●	●	●	●	●	●	●	78
BFL20-RHF	●	●	●	●	●	●	●	●	●	●	●	78
BFL20-Niro	●	●	●	●	●	●	●	●	●	●	●	79
BFL32												
BFL32	●	●	●	●	●	●	●	●	●	●	●	80
BFL32-Aramid	●	●	●	●	●	●	●	●	●	●	●	80
BFL32-HF	●	●	●	●	●	●	●	●	●	●	●	81
BFL32-RSL	●	●	●	●	●	●	●	●	●	●	●	81
BFL32-RKV	●	●	●	●	●	●	●	●	●	●	●	82
BFL32-RHF	●	●	●	●	●	●	●	●	●	●	●	82
BFL38												
BFL38	●	●	●	●	●	●	●	●	●	●	●	83
BFL48												
BFL48	●	●	●	●	●	●	●	●	●	●	●	83

- STANDARD
- ON REQUEST

Specifications can change without prior notice.
Please contact our Applications Engineering for specific „minus“ and length tolerances.
For further configurations please contact our Application Consulting.
Please find used abbreviations on page 162.

LINEAR BELTS

FLAT BELTS BLACK-FLAT

GATES BFL20 ◀▶

Belt Thickness	2 mm				
Standard Roll Length ($\pm 1\%$)	100 m				
Standard Color	Black				
Width Tolerance					
up to 50 mm Width	± 0.5 mm				
> 50 mm Width	± 0.75 mm				
Minimum Welded Belt Length					
up to 100 mm Width	880 mm				
> 100 mm Width	960 mm				
Minimum Pulley Diameter	45 mm				
Minimum Back Bend Diameter	67.5 mm				
Specific Belt Mass m_{sp}	0.0030 kg/m/mm				
Standard Width [mm]	25	50	75	100	150
Tensile Strength (Average Value)					
F_{Break} [N]	7140	14 700	22 260	29 820	44 940
Allowable Belt Force					
F_{1alt} [N] Open Ended	2 386	4 912	7 438	9 963	15 015
Allowable Belt Force					
F_{1alt} [N] Endless Welded	1 193	2 456	3 719	4 982	7 508
Specific Belt Stiffness c_{sp} [N]	477 125	982 316	1 487 507	1 992 699	3 003 081

GATES BFL20 ◀▶ ARAMID

Belt Thickness	2 mm				
Standard Roll Length ($\pm 1\%$)	100 m				
Standard Color	Black				
Width Tolerance					
up to 50 mm Width	± 0.5 mm				
> 50 mm Width	± 0.75 mm				
Minimum Welded Belt Length					
up to 100 mm Width	880 mm				
> 100 mm Width	960 mm				
Minimum Pulley Diameter	45 mm				
Minimum Back Bend Diameter	67.5 mm				
Specific Belt Mass m_{sp}	0.0023 kg/m/mm				
Standard Width [mm]	25	50	75	100	150
Tensile Strength (Average Value)					
F_{Break} [N]	8 085	16 709	25 333	33 957	51 205
Allowable Belt Force					
F_{1alt} [N] Open Ended	1 329	2 747	4 165	5 583	8 419
Allowable Belt Force					
F_{1alt} [N] Endless Welded	665	1 374	2 083	2 792	4 210
Specific Belt Stiffness c_{sp} [N]	265 875	549 475	833 075	1 116 675	1 683 875

BFL20

GATES BFL20 ↔ HF

Belt Thickness	2 mm				
Standard Roll Length ($\pm 1\%$)	100 m				
Standard Color	Black				
Width Tolerance up to 50 mm Width > 50 mm Width	± 0.5 mm ± 0.75 mm				
Minimum Welded Belt Length up to 100 mm Width > 100 mm Width	880 mm 960 mm				
Minimum Pulley Diameter	38 mm				
Minimum Back Bend Diameter	57 mm				
Specific Belt Mass m_{sp}	0.0033 kg/m/mm				
Standard Width [mm]	25	50	75	100	150
Tensile Strength (Average Value) F_{Break} [N]	10 540	21 700	32 860	44 020	66 340
Allowable Belt Force F_{1all} [N] Open Ended	2 925	6 022	9 119	12 216	18 410
Allowable Belt Force F_{1all} [N] Endless Welded	1 463	3 011	4 560	6 108	9 205
Specific Belt Stiffness c_{sp} [N]	585 000	1 204 412	1 823 824	2 443 235	3 682 059

GATES BFL20 ↔ RSL

Belt Thickness	2 mm				
Standard Roll Length ($\pm 1\%$)	100 m				
Standard Color	Black				
Width Tolerance up to 50 mm Width > 50 mm Width	± 0.75 mm ± 1.0 mm				
Minimum Welded Belt Length up to 100 mm Width > 100 mm Width	880 mm 960 mm				
Minimum Pulley Diameter	48 mm				
Minimum Back Bend Diameter	72 mm				
Specific Belt Mass m_{sp}	0.0038 kg/m/mm				
Standard Width [mm]	25	50	75	100	150
Tensile Strength (Average Value) F_{Break} [N]	14 250	29 450	44 650	59 850	90 250
Allowable Belt Force F_{1all} [N] Open Ended	4 676	9 664	14 652	19 640	29 616
Allowable Belt Force F_{1all} [N] Endless Welded	2 338	4 832	7 326	9 820	14 808
Specific Belt Stiffness c_{sp} [N]	935 250	1 932 850	2 930 450	3 928 050	5 923 250

TIMING BELTS

SELF TRACKING

FLAT BELTS

WIDE BELTS

ENDLESS BELTS

FINISHING

INFORMATION

LINEAR BELTS

FLAT BELTS BLACK-FLAT

TIMING BELTS

SELF TRACKING

FLAT BELTS

WIDE BELTS

ENDLESS BELTS

FINISHING

INFORMATIONEN

GATES BFL20 ↔ RKV

Belt Thickness		2 mm				
Standard Roll Length ($\pm 1\%$)		100 m				
Standard Color		Black				
Width Tolerance						
up to 50 mm Width		± 0.75 mm				
> 50 mm Width		± 1.0 mm				
Minimum Welded Belt Length						
up to 100 mm Width		880 mm				
> 100 mm Width		960 mm				
Minimum Pulley Diameter		48 mm				
Minimum Back Bend Diameter		72 mm				
Specific Belt Mass m_{sp}		0.0022 kg/m/mm				
Standard Width [mm]		25	50	75	100	150
Tensile Strength (Average Value)						
F_{Break} [N]		16 158	33 449	50 713	67 977	102 505
Allowable Belt Force						
F_{1alt} [N] Open Ended		2 188	4 521	6 854	9 188	13 854
Allowable Belt Force						
F_{1alt} [N] Endless Welded		1 094	2 260	3 427	4 594	6 927
Specific Belt Stiffness c_{sp} [N]		437 500	904 167	1 370 833	1 837 500	2 770 833

GATES BFL20 ↔ RHF

Belt Thickness		2 mm				
Standard Roll Length ($\pm 1\%$)		100 m				
Standard Color		Black				
Width Tolerance						
up to 50 mm Width		± 0.75 mm				
> 50 mm Width		± 1.0 mm				
Minimum Welded Belt Length						
up to 100 mm Width		880 mm				
> 100 mm Width		960 mm				
Minimum Pulley Diameter		38 mm				
Minimum Back Bend Diameter		57 mm				
Specific Belt Mass m_{sp}		0.0035 kg/m/mm				
Standard Width [mm]		25	50	75	100	150
Tensile Strength (Average Value)						
F_{Break} [N]		12 975	26 815	40 655	54 495	82 175
Allowable Belt Force						
F_{1alt} [N] Open Ended		4 320	8 928	13 536	18 144	27 360
Allowable Belt Force						
F_{1alt} [N] Endless Welded		2 160	4 464	6 768	9 072	13 680
Specific Belt Stiffness c_{sp} [N]		864 000	1 785 600	2 707 200	3 628 800	5 472 000

BFL20

GATES BFL20 ↔ NIRO

Belt Thickness	2 mm				
Standard Roll Length ($\pm 1\%$)	100 m				
Standard Color	Black				
Width Tolerance up to 50 mm Width	± 0.75 mm				
> 50 mm Width	± 1.0 mm				
Minimum Welded Belt Length up to 100 mm Width	880 mm				
> 100 mm Width	960 mm				
Minimum Pulley Diameter	64 mm				
Minimum Back Bend Diameter	96 mm				
Specific Belt Mass m_{sp}	0.0037 kg/m/mm				
Standard Width [mm]	25	50	75	100	150
Tensile Strength (Average Value) F_{Break} [N]	10 688	22 088	33 488	44 888	67 688
Allowable Belt Force F_{1all} [N] Open Ended	3 507	7 248	10 989	14 730	22 212
Allowable Belt Force F_{1all} [N] Endless Welded	1 754	3 624	5 495	7 365	11 106
Specific Belt Stiffness c_{sp} [N]	701 438	1 449 639	2 197 839	2 946 040	4 442 441

TIMING BELTS

SELF TRACKING

FLAT BELTS

WIDE BELTS

ENDLESS BELTS

FINISHING

INFORMATION

LINEAR BELTS

FLAT BELTS BLACK-FLAT

TIMING BELTS

SELF TRACKING

FLAT BELTS

WIDE BELTS

ENDLESS BELTS

FINISHING

INFORMATIONEN

GATES BFL32 ◊

Belt Thickness	3.2 mm				
Standard Roll Length ($\pm 1\%$)	100 m				
Standard Color	Black				
Width Tolerance					
up to 50 mm Width	± 0.5 mm				
> 50 mm Width	± 0.75 mm				
Minimum Welded Belt Length					
up to 100 mm Width	880 mm				
> 100 mm Width	960 mm				
Minimum Pulley Diameter	60 mm				
Minimum ack Bend Diameter	120 mm				
Specific Belt Mass m_{sp}	0.0044 kg/m/mm				
Standard Width [mm]	25	50	75	100	150
Tensile Strength (Average Value)					
F_{Break} [N]	7 140	14 700	22 260	29 820	44 940
Allowable Belt Force					
F_{1alt} [N] Open Ended	2 386	4 912	7 438	9 963	15 015
Allowable Belt Force					
F_{1alt} [N] Endless Welded	1 193	2 456	3 719	4 982	7 508
Specific Belt Stiffness c_{sp} [N]	477 125	982 316	1 487 507	1 992 699	3 003 081

GATES BFL32 ◊ ARAMID

Belt Thickness	3.2 mm				
Standard Roll Length ($\pm 1\%$)	100 m				
Standard Color	Black				
Width Tolerance					
up to 50 mm Width	± 0.5 mm				
> 50 mm Width	± 0.75 mm				
Minimum Welded Belt Length					
up to 100 mm Width	880 mm				
> 100 mm Width	960 mm				
Minimum Pulley Diameter	60 mm				
Minimum ack Bend Diameter	120 mm				
Specific Belt Mass m_{sp}	0.0037 kg/m/mm				
Standard Width [mm]	25	50	75	100	150
Tensile Strength (Average Value)					
F_{Break} [N]	8 085	16 709	25 333	33 957	51 205
Allowable Belt Force					
F_{1alt} [N] Open Ended	1 329	2 747	4 165	5 583	8 419
Allowable Belt Force					
F_{1alt} [N] Endless Welded	665	1 374	2 083	2 792	4 210
Specific Belt Stiffness c_{sp} [N]	265 875	549 475	833 075	1 116 675	1 683 875

BFL32

GATES BFL32 ↔ HF

Belt Thickness	3.2 mm				
Standard Roll Length (± 1%)	100 m				
Standard Color	Black				
Width Tolerance up to 50 mm Width	± 0.5 mm				
> 50 mm Width	± 0.75 mm				
Minimum Welded Belt Length up to 100 mm Width	880 mm				
> 100 mm Width	960 mm				
Minimum Pulley Diameter	50 mm				
Minimum Slack Bend Diameter	105 mm				
Specific Belt Mass m_{sp}	0.0048 kg/m/mm				
Standard Width [mm]	25	50	75	100	150
Tensile Strength (Average Value) F_{Break} [N]	10 540	21 700	32 860	44 020	66 340
Allowable Belt Force F_{1all} [N] Open Ended	2 925	6 022	9 119	12 216	18 410
Allowable Belt Force F_{1all} [N] Endless Welded	1 463	3 011	4 560	6 108	9 205
Specific Belt Stiffness c_{sp} [N]	585 000	1 204 412	1 823 824	2 443 235	3 682 059

GATES BFL32 ↔ RSL

Belt Thickness	3.2 mm				
Standard Roll Length (± 1%)	100 m				
Standard Color	Black				
Width Tolerance up to 50 mm Width	± 1.0 mm				
> 50 mm Width	± 1.5 mm				
Minimum Welded Belt Length up to 100 mm Width	880 mm				
> 100 mm Width	960 mm				
Minimum Pulley Diameter	80 mm				
Minimum Slack Bend Diameter	120 mm				
Specific Belt Mass m_{sp}	0.0062 kg/m/mm				
Standard Width [mm]	25	50	75	100	150
Tensile Strength (Average Value) F_{Break} [N]	24 220	50 170	76 120	102 070	153 970
Allowable Belt Force F_{1all} [N] Open Ended	7 325	15 173	23 021	30 870	46 566
Allowable Belt Force F_{1all} [N] Endless Welded	3 663	7 587	11 511	15 435	23 283
Specific Belt Stiffness c_{sp} [N]	1 465 000	3 034 643	4 604 286	6 173 929	9 313 214

LINEAR BELTS

FLAT BELTS BLACK-FLAT

TIMING BELTS

SELF TRACKING

FLAT BELTS

WIDE BELTS

ENDLESS BELTS

FINISHING

INFORMATIONEN

GATES BFL32 ◊ RKV

Belt Thickness	3.2 mm				
Standard Roll Length ($\pm 1\%$)	100 m				
Standard Color	Black				
Width Tolerance					
up to 50 mm Width	± 1.0 mm				
> 50 mm Width	± 1.5 mm				
Minimum Welded Belt Length					
up to 100 mm Width	880 mm				
> 100 mm Width	960 mm				
Minimum Pulley Diameter	80 mm				
Minimum Back Bend Diameter	120 mm				
Specific Belt Mass m_{sp}	0.0035 kg/m/mm				
Standard Width [mm]	25	50	75	100	150
Tensile Strength (Average Value)					
F_{Break} [N]	21 798	45 153	65 508	91 863	138 573
Allowable Belt Force					
F_{1alt} [N] Open Ended	2 188	4 531	6 875	9 219	13 906
Allowable Belt Force					
F_{1alt} [N] Endless Welded	1 094	2 266	3 438	4 609	6 953
Specific Belt Stiffness c_{sp} [N]	437 500	906 250	1 375 000	1 843 750	2 781 250

GATES BFL32 ◊ RHF

Belt Thickness	3.2 mm				
Standard Roll Length ($\pm 1\%$)	100 m				
Standard Color	Black				
Width Tolerance					
up to 50 mm Width	± 1.0 mm				
> 50 mm Width	± 1.5 mm				
Minimum Welded Belt Length					
up to 100 mm Width	880 mm				
> 100 mm Width	960 mm				
Minimum Pulley Diameter	64 mm				
Minimum Back Bend Diameter	96 mm				
Specific Belt Mass m_{sp}	0.0066 kg/m/mm				
Standard Width [mm]	25	50	75	100	150
Tensile Strength (Average Value)					
F_{Break} [N]	26 950	55 825	84 700	113 575	171 325
Allowable Belt Force					
F_{1alt} [N] Open Ended	6 349	13 151	19 953	26 755	40 360
Allowable Belt Force					
F_{1alt} [N] Endless Welded	3 174	6 575	9 977	13 378	20 180
Specific Belt Stiffness c_{sp} [N]	1 269 750	2 630 196	3 990 643	5 351 089	8 071 982

BFL32/38/48

GATES BFL38 ◀▶

Belt Thickness	3.8 mm				
Standard Roll Length ($\pm 1\%$)	50 m				
Standard Color	Black				
Width Tolerance	± 2.0 mm				
Minimum Welded Belt Length	No Welding				
Minimum Pulley Diameter	160 mm				
Minimum Back Bend Diameter	160 mm				
Specific Belt Mass m_{sp}	0.0079 kg/m/mm				
Standard Width [mm]	25	50	75	100	150
Tensile Strength (Average Value) F_{Break} [N]	33 600	70 400	107 200	144 000	217 600
Allowable Belt Force F_{1all} [N] Open Ended	8 892	19 563	29 345	40 016	60 469
Specific Belt Stiffness c_{sp} [N]	1 778 498	3 912 696	5 869 043	8 003 241	12 093 786

GATES BFL48 ◀▶

Belt Thickness	4.8 mm				
Standard Roll Length (Tolerance $\pm 1\%$)	50 m				
Standard Color	Black				
Width Tolerance	± 2.0 mm				
Minimum Welded Belt Length	No Welding				
Minimum Pulley Diameter	150 mm				
Minimum Back Bend Diameter	225 mm				
Specific Belt Mass m_{sp}	0.0108 kg/m/mm				
Standard Width [mm]	25	50	75	100	150
Tensile Strength (Average Value) F_{Break} [N]	45 000	97 500	150 000	202 500	307 500
Allowable Belt Force F_{1all} [N] Open Ended	13 378	28 986	44 594	60 201	91 417
Specific Belt Stiffness c_{sp} [N]	2 675 622	5 797 181	8 918 740	12 040 299	18 283 417

TIMING BELTS

SELF TRACKING

FLAT BELTS

WIDE BELTS

ENDLESS BELTS

FINISHING

INFORMATION

LINEAR BELTS

CLAMP CONNECTION FIX-FLAT

TIMING BELTS

SELF-TRACKING

FLAT BELTS

WIDE BELTS

ENDLESS BELTS

FINISHING

INFORMATIONEN

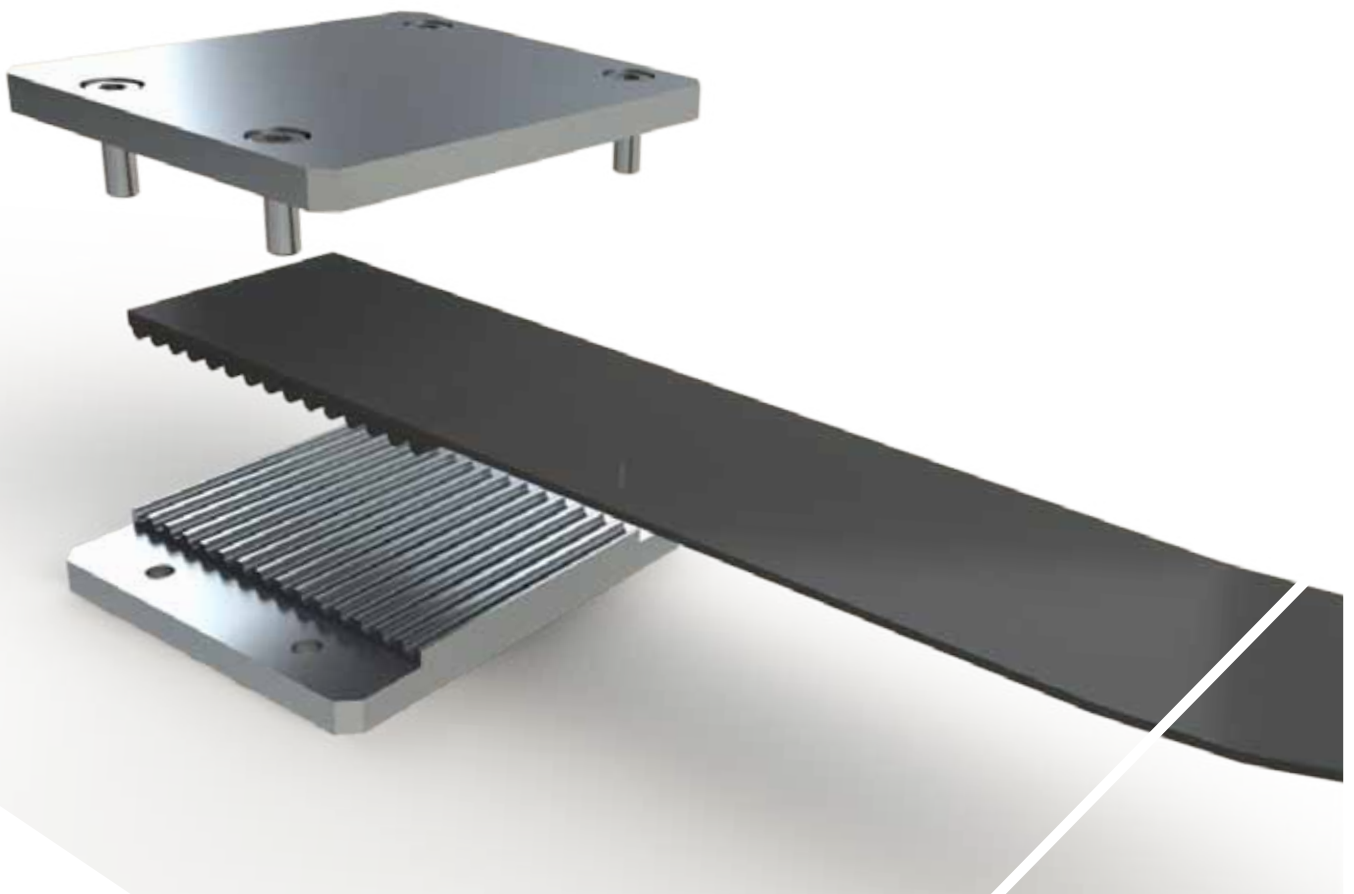



FIX-FLAT — The new Flat Belt Clamp holds all Types of Flat Belts easily and safely!

With our latest, patent pending process, you can clamp all belts easily, quickly and safely. The FIX-FLAT process is suitable for all BLACK-FLAT belt constructions. More information is available on request!

FEATURES

- › Suitable for all types of flat belts.
- › Easy
- › Safe
- › Fast

CONTACT:

- › *Phone:* +49 (0)6157 9727-0
- › *E-Mail:* Info-Pfungstadt@gates.com

LINEAR BELTS

WIDE BELTS

TIMING BELTS

SELF TRACKING

FLAT BELTS

WIDE BELTS

ENDLESS BELTS

FINISHING

INFORMATION

Gates Wide Belts are commonly used in applications which require an exact product positioning. A parallel construction of high strength aramid cords ensure even tension and smooth running characteristics. The belt construction of high-strength polyurethane is cut resistant and non-marking. Those belts stand out in addition of easy cleaning and smooth belt drive and are ideal replacement for plastic modular belts and conveyor belts.

ATTRIBUTES

- › Easy to clean
- › Cut resistant
- › Widths up to 450 mm available
- › Suitable for synchronous conveying applications
- › No cord exposure at the edges of the belt
- › Low-noise, smooth operation
- › FDA approval for: WT10 / WH and GMT3™
- › EU food approval for: GMT3™

APPLICATIONS

- › Synchronous conveying applications
- › Bulk conveying
- › Food and confectionary conveying
- › Clean room or wash down environments
- › Hygienic applications

PROCESSING OPTIONS

- › Backings *Further information on page 124*
- › Profiles *Further information on page 138*
- › Special processing *Further information on page 146*

WIDE BELTS	FABRIC BACKING				POLYURETHANE				Page
	No Fabric	NT-Polyamide Fabric Tooth Side	NB-Polyamide Fabric Back	NTB-Polyamide Fabric Both Sides	R1-92 Shore A	R2-85 Shore A	R4-94 Shore A / Antistatic	EU-Approval	
WH	●	●	●	●	●	●	●	●	89
WT10	●	●	●	●	●	●	●	●	91
GMT3™					●		●	●	93

- STANDARD
- ON REQUEST

Specifications can change without prior notice.
Please contact our Applications Engineering for specific „minus“ and length tolerances.
For further configurations please contact our Application Consulting.
Please find used abbreviations on page 162.

LINEAR BELTS

WIDE BELTS

TIMING BELTS

SELF-TRACKING

FLAT BELTS

WIDE BELTS

ENDLESS BELTS

FINISHING

INFORMATION

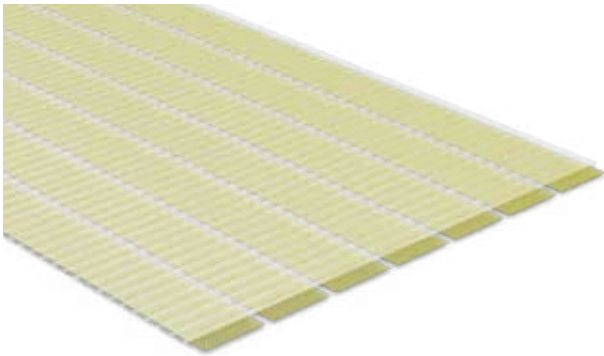

Pitch	0.500" / 12.7 mm
Standard Color	CLEAR
Standard Roll Length ($\pm 1\%$)	200 feet / 61 m
Width Tolerance	+ 1.0 mm / - 2.0 mm
Sitting Lanes	2.5" / 63.5 mm
Minimum Welded Belt Length	43.5" / 1 104.9 mm
Minimum Number of Pulley Teeth z_{\min}	14
Minimum Pulley Diameter	2.23" / 56.64 mm
Minimum Back Bend Diameter	3.12" / 79.24 mm
FDA Approval	Yes

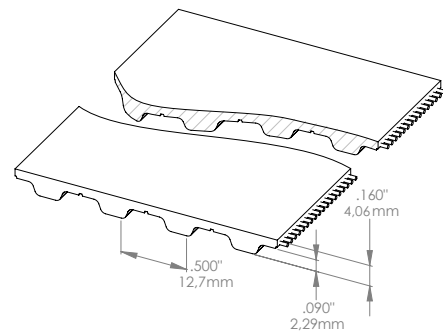

Standard Width (Inch)	6	8	10	12	13	18
Tensile Strength (Average Value) F_{Break} (N)						
Aramid	21 021	28 028	35 574	42 581	46 354	64 141
Allowable Belt Force F_{1all} (N) Open Ended						
Aramid	3 180	4 240	5 300	6 360	6 890	9 540
Allowable Belt Force F_{1all} (N) Endless Welded						
Aramid	2 385	3 180	3 975	4 770	5 168	7 155
Allowable Effective Force F_{eall} (N)						
(Minimum 15 teeth are in mesh)	8 820	11 760	14 700	17 640	19 110	26 460
Specific Belt Mass m_{sp} (kg/m/mm)						
Aramid	0.0033					
Specific Belt Stiffness c_{sp} (N)						
Aramid	795 000	1 060 000	1 325 000	1 590 000	1 722 500	2 385 000

LINEAR BELTS

WIDE BELTS

TIMING BELTS

SELF-TRACKING

FLAT BELTS

WIDE BELTS

ENDLESS BELTS

FINISHING

INFORMATION

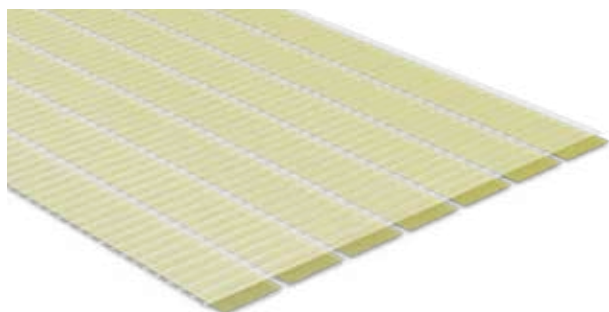

Pitch	10 mm
Standard Color	CLEAR
Standard Roll Length ($\pm 1\%$)	60 m
Width Tolerance	+ 1.0 mm / - 2.0 mm
Sitting Lanes	64 mm
Minimum Welded Belt Length	1 100 mm
Minimum Number of Pulley Teeth z_{min}	14
Minimum Pulley Diameter	44.56 mm
Minimum Back Bend Diameter	80 mm
FDA Approval	Yes

WT10

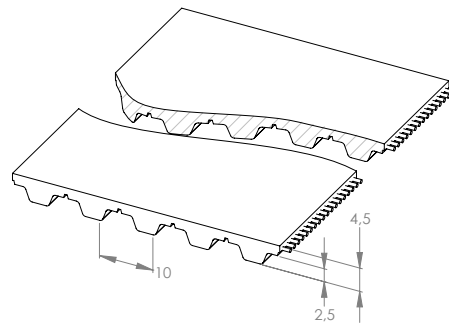

Standard Width (mm)	150	200	250	300	325	450
Tensile Strength (Average Value) F_{Break} (N)						
Aramid	21 021	28 028	35 574	42 581	46 354	64 141
Allowable Belt Force F_{1all} (N) Open Ended						
Aramid	3 180	4 240	5 300	6 360	6 890	9 540
Allowable Belt Force F_{1all} (N) Endless Welded						
Aramid	2 385	3 180	3 975	4 770	5 168	7 155
Allowable Effective Force F_{eall} (N)						
(Minimum 15 teeth are in mesh)	7 500	10 000	12 500	15 000	16 250	22 500
Specific Belt Mass m_{sp} (kg/m/mm)						
Aramid	0.0039					
Specific Belt Stiffness c_{sp} (N)						
Aramid	795 000	1 060 000	1 325 000	1 590 000	1 722 500	2 385 000

TIMING BELTS

SELF TRACKING

FLAT BELTS

WIDE BELTS

ENDLESS BELTS

FINISHING

INFORMATION

LINEAR BELTS

WIDE BELTS

TIMING BELTS

SELF-TRACKING

FLAT BELTS

WIDE BELTS

ENDLESS BELTS

FINISHING

INFORMATION

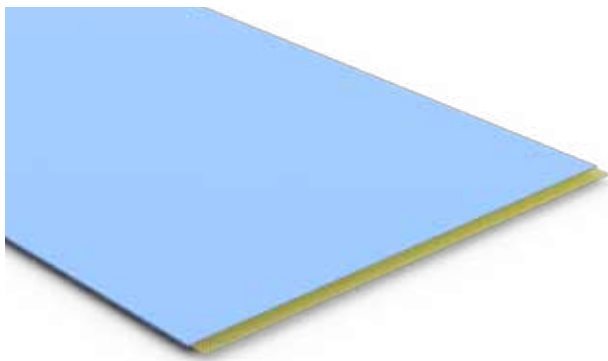

Pitch	3 mm
Standard Color	Blue
Standard Roll Length ($\pm 1\%$)	60 m
Width Tolerance	+ 1.0 mm / - 2.0 mm
Sitting Lanes	Without Sitting Lanes
Minimum Welded Belt Length	1 200 mm
Minimum Number of Pulley Teeth z_{\min}	19
Minimum Pulley Diameter	19 mm
Minimum Back Bend Diameter	30 mm
FDA/EU Approval	Yes

GMT3™

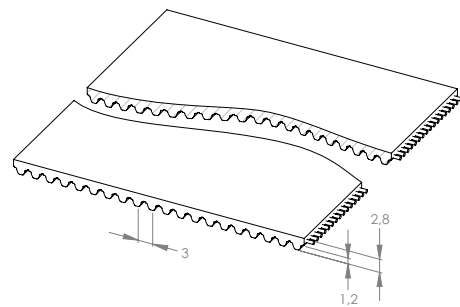

Standard Width (mm)	50	100	150	200	250	300	450
Tensile Strength (Average Value) F_{Break} (N)							
Aramid	3 861	7 847	11 833	15 819	19 804	24 039	35 747
Allowable Belt Force F_{1all} (N) Open Ended							
Aramid	587	1 174	1 761	2 348	2 935	3 522	5 283
Allowable Belt Force F_{1all} (N) Endless Welded							
Aramid	440	881	1 321	1 761	2 201	2 642	3 962
Allowable Effective Force F_{eall} (N)							
(Minimum 15 teeth are in mesh)	700	1 400	2 100	2 800	3 500	4 200	6 300
Specific Belt Mass m_{sp} (kg/m/mm)							
Aramid	0.0020						
Specific Belt Stiffness c_{sp} (N)							
Aramid	146 750	293 500	440 250	587 000	733 750	880 500	1 320 750

TIMING BELTS

SELF TRACKING

FLAT BELTS

WIDE BELTS

ENDLESS BELTS

FINISHING

INFORMATION

ENDLESS BELTS

**GATES SYNCHRO-POWER® -
TRULY ENDLESS (CAST) BELTS**

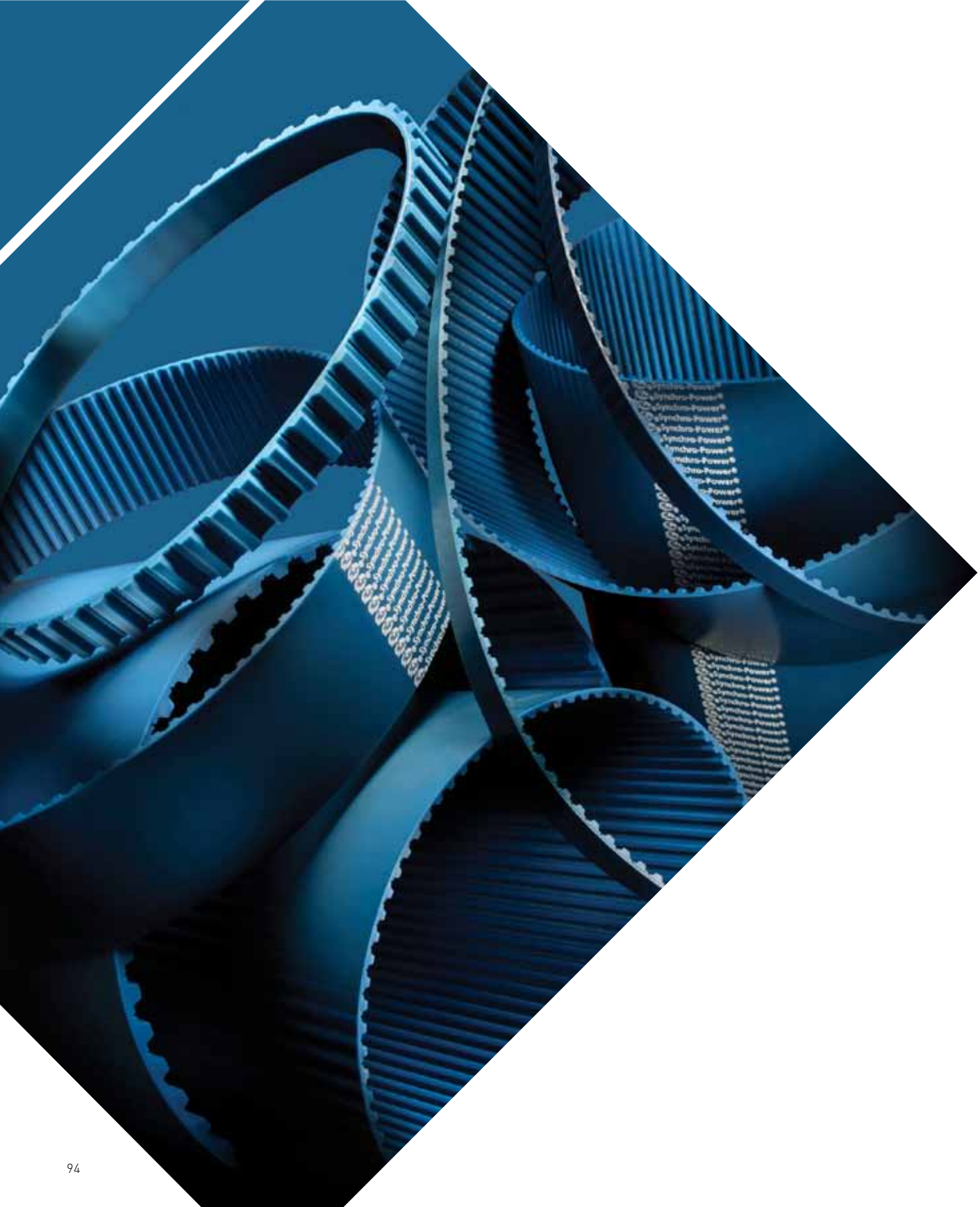

Certain power transmission and high performance positioning applications require more strength and stiffness than a welded belt can provide. Gates offers two types of truly endless belts to meet these demands.

Gates Synchro-Power® Cast Belts are cast on fixed molds and have continuously wounded steel cords. They are manufactured in various exact sizes, constructions and pitches to fulfill customer requirements.

Cast Belts offer premium capacity for power transmissions and linear applications while fitting a broad range of loads, speeds and applications.

ATTRIBUTES

- › Molded, thermo-set polyurethane construction
- › Full load and power transmission based on endless cords
- › Excellent abrasion resistance
- › Smooth, low noise, non-marking operation
- › High tooth strength reduces deforming under load
- › Excellent resistance to chemicals

APPLICATIONS

- › Paper processing industry
- › Wood processing industry
- › Glass processing industry
- › Textile industry
- › Packaging machines
- › Exercise equipment

PROCESSING OPTIONS

- › Backings *Further information on page 124*
- › Special processing *Further information on page 146*

FABRICATION CAPABILITIES

- › Pitches T2,5 / T5 / T10 / DT5 / DT10 / AT5 / AT10
- › Widths 4 mm up to 380 mm
- › Lengths 120 mm up to 2 250 mm
- › Polyurethane 88 Shore A (Standard)
- › Tension members Steel cord (Standard)
Aramid cord available on request
- › Polyamide fabric Not available

Further constructions are available on request.

ENDLESS BELTS

GATES SYNCHRO-POWER® - TRULY ENDLESS (CAST) BELTS

TIMING BELTS

SELF-TRACKING

FLAT BELTS

WIDE BELTS

ENDLESS BELTS

FINISHING

INFORMATION

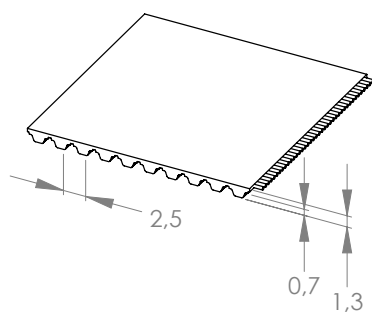

Pitch	2.5 mm
Standard Color	Blue
Width Tolerance complete Sleeve	± 3.0 mm
Minimum Number of Pulley Teeth z_{min}	12
Minimum Pulley Diameter	9,55 mm
Minimum Back Bend Diameter	20 mm
FDA/EU Approval	No

Standard Width (mm)	4	6	10	12	16	20	25	32	50
Tensile Strength (Average Value) F_{Break} (N)									
Steel	330	535	990	1 195	1 670	2 085	2 670	3 390	5 395
Allowable Belt Force F_{1all} (N)									
Steel	83	134	248	299	418	521	668	848	1 349
Allowable Effective Force F_{eall} (N)									
(Minimum 15 teeth are in mesh)	43	65	108	130	173	216	270	346	540

T2.5

Länge (mm)	Width (mm)	No. of Teeth
120	200	48
145	200	59
160	200	64
177.5	200	71
180	200	72
200	200	80
210	200	84
230	200	92
245	200	98
265	200	106
277.5	200	111
285	200	114
290	200	116
305	200	122

Länge (mm)	Width (mm)	No. of Teeth
317.5	200	127
330	380	132
342.5	200	137
380	380	152
420	380	168
480	380	192
500	380	200
540	380	216
600	380	240
620	380	248
650	380	260
780	380	312
915	380	366
950	380	380

TIMING BELTS

SELF TRACKING

FLST BELTS

WIDE BELTS

ENDLESS BELTS

FINISHING

INFORMATION

ENDLESS BELTS

GATES SYNCHRO-POWER® - TRULY ENDLESS (CAST) BELTS

TIMING BELTS

SELF-TRACKING

FLAT BELTS

WIDE BELTS

ENDLESS BELTS

FINISHING

INFORMATION

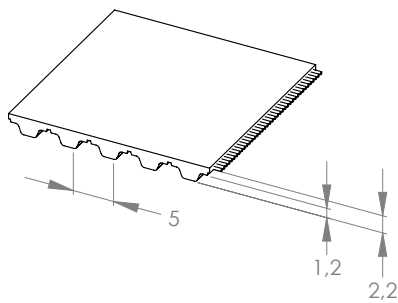

Pitch	5 mm
Standard Color	Blue
Width Tolerance complete Sleeve	± 3.0 mm
Minimum Number of Pulley Teeth z_{min}	10
Minimum Pulley Diameter	15,91 mm
Minimum Back Bend Diameter	30 mm
FDA/EU Approval	No

Standard Width (mm)	6	10	12	16	20	25	32	50	75
Tensile Strength (Average Value) F_{Break} (N)									
Steel	870	1 495	1 870	2 640	3 350	4 240	5 500	8 590	13 180
Allowable Belt Force F_{1all} (N)									
Steel	202	336	403	538	672	840	1 075	1 680	2 520
Allowable Effective Force F_{eall} (N)									
(Minimum 15 teeth are in mesh)	214	356	427	570	712	890	1 139	1 780	2 670
Specific Belt Stiffness c_{sp} (N)									
Steel	50 400	84 000	100 800	134 400	168 000	210 000	268 800	420 000	630 000

T5

Länge (mm)	Width (mm)	No. of Teeth
165	200	33
185	200	37
200	200	40
215	200	43
220	200	44
225	200	45
245	200	49
250	200	50
255	200	51
260	200	52
270	200	54
275	200	55
280	200	56
295	200	59
300	200	60
305	200	61
320	200	64
325	380	65
330	380	66
340	380	68
350	380	70
355	380	71
365	380	73
375	380	75
390	380	78

Länge (mm)	Width (mm)	No. of Teeth
400	380	80
410	380	82
420	380	84
425	380	85
430	380	86
440	380	88
445	380	89
450	380	90
455	380	91
460	380	92
475	380	95
480	380	96
500	380	100
510	380	102
525	380	105
545	380	109
550	380	110
560	380	112
575	380	115
590	380	118
600	380	120
610	380	122
620	380	124
625	380	125
630	380	126

Länge (mm)	Width (mm)	No. of Teeth
640	380	128
650	380	130
660	380	132
675	380	135
690	380	138
700	380	140
720	380	144
725	380	145
750	380	150
780	380	156
800	380	160
815	380	163
840	380	168
850	380	170
900	380	180
940	380	188
990	380	198
1 000	380	200
1 075	380	215
1 100	380	220
1 215	380	243
1 315	380	263
1 350	380	270
1 380	380	276
1 440	380	288

TIMING BELTS

SELF TRACKING

FLST BELTS

WIDE BELTS

ENDLESS BELTS

FINISHING

INFORMATION

ENDLESS BELTS

GATES SYNCHRO-POWER® - TRULY ENDLESS (CAST) BELTS

TIMING BELTS

SELF TRACKING

FFLAT BELTS

WIDE BELTS

ENDLESS BELTS

FINISHING

INFORMATION

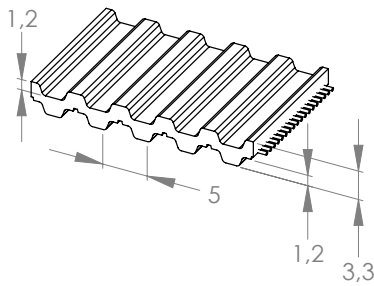

Pitch	5 mm
Standard Color	Blue
Width Tolerance complete Sleeve	± 3.0 mm
Minimum Number of Pulley Teeth z_{min}	10
Minimum Pulley Diameter	15.91 mm
Minimum Back Bend Diameter	15.91 mm
FDA/EU Approval	No

Standard Width (mm)	6	10	12	16	20	25	32	50	75
Tensile Strength (Average Value) F_{Break} (N)									
Steel	870	1 495	1 870	2 640	3 350	4 240	5 500	8 590	13 180
Allowable Belt Force F_{1all} (N)									
Steel	202	336	403	538	672	840	1 075	1 680	2 520
Allowable Effective Force F_{eall} (N)									
(Minimum 15 teeth are in mesh)	214	356	427	570	712	890	1 139	1 780	2 670
Specific Belt Stiffness c_{sp} (N)									
Steel	50 400	84 000	100 800	134 400	168 000	210 000	268 800	420 000	630 000

DT5

Length (mm)	Width (mm)	No of Teeth
300	200	60
400	200	80
410	380	82
450	200	90
460	380	92
480	380	96
500	200	100
515	380	103
550	200	110
590	380	118
600	200	120
620	380	124
650	200	130
700	200	140
750	380	150
815	380	163
900	200	180
940	380	188
1 100	380	220

TIMING BELTS

SELF TRACKING

FLST BELTS

WIDE BELTS

ENDLESS BELTS

FINISHING

INFORMATION

ENDLESS BELTS

GATES SYNCHRO-POWER® - TRULY ENDLESS (CAST) BELTS

TIMING BELTS

SELF-TRACKING

FLAT BELTS

WIDE BELTS

ENDLESS BELTS

FINISHING

INFORMATION

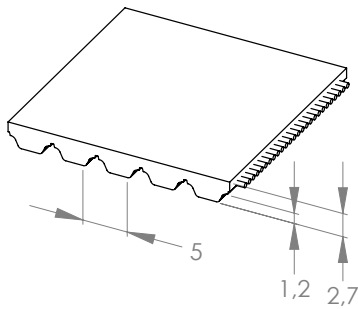

Pitch	5 mm
Standard Color	Blue
Width Tolerance complete Sleeve	± 3.0 mm
Minimum Number of Pulley Teeth z_{min}	15
Minimum Pulley Diameter	23.87 mm
Minimum Back Bend Diameter	60 mm
FDA/EU Approval	No

Standard Width (mm)	6	10	12	16	20	25	32	50	75
Tensile Strength (Average Value) F_{Break} (N)									
Steel	1 410	2 865	3 720	5 110	6 560	8 300	10 785	17 090	26 200
Allowable Belt Force F_{1all} (N)									
Steel	423	704	845	1 127	1 408	1 761	2 253	3 521	5 282
Allowable Effective Force F_{eall} (N)									
(Minimum 15 teeth are in mesh)	310	516	619	826	1 032	1 290	1 651	2 580	3 870
Specific Belt Stiffness c_{sp} (N)									
Steel	105 630	176 050	211 260	281 680	352 100	440 125	563 360	880 250	1 320 375

AT5

Length (mm)	Width (mm)	No of Teeth
225	200	45
280	200	56
300	200	60
340	380	68
375	380	75
390	380	78
420	380	84
450	200	90
455	380	91
500	380	100
545	380	109
600	380	120
610	380	122
660	380	132
710	200	142
720	380	144
750	380	150
780	380	156
825	380	165
860	200	172
975	380	195
1 050	380	210
1 500	380	300

TIMING BELTS

SELF TRACKING

FLST BELTS

WIDE BELTS

ENDLESS BELTS

FINISHING

INFORMATION

ENDLESS BELTS

GATES SYNCHRO-POWER® - TRULY ENDLESS (CAST) BELTS

TIMING BELTS

SELF-TRACKING

FLAT BELTS

WIDE BELTS

ENDLESS BELTS

FINISHING

INFORMATION

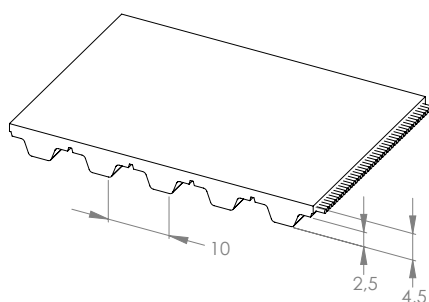

Pitch	10 mm
Standard Color	Blue
Width Tolerance complete Sleeve	± 3.0 mm
Minimum Number of Pulley Teeth z_{min}	14
Minimum Pulley Diameter	44.56 mm
Minimum Back Bend Diameter	80 mm
FDA/EU Approval	No

Standard Width (mm)	10	12	16	20	25	32	50	75
Tensile Strength (Average Value) F_{Break} (N)								
Steel	3 350	4 195	5 910	7 585	9 700	12 580	20 190	30 710
Allowable Belt Force F_{Tall} (N)								
Steel	763	916	1 221	1 527	1 909	2 443	3 817	5 726
Allowable Effective Force F_{eall} (N)								
(Minimum 15 teeth are in mesh)	676	811	1 082	1 352	1 690	2 163	3 380	5 070
Specific Belt Stiffness c_{sp} (N)								
Steel	190 850	229 020	305 360	381 700	477 125	610 720	954 250	1 431 375

T10

Length (mm)	Width (mm)	No. of Teeth
260	200	26
320	200	32
370	380	37
400	380	40
410	380	41
440	380	44
450	380	45
500	380	50
530	380	53
550	200	55
560	380	56
600	380	60
610	380	61
630	380	63
650	200	65
660	380	66
690	380	69
700	380	70
720	380	72
750	380	75
780	380	78
800	380	80

Length (mm)	Width (mm)	No of Teeth
810	380	81
840	380	84
850	380	85
880	380	88
890	380	89
900	380	90
910	380	91
920	380	92
950	380	95
960	380	96
970	380	97
980	380	98
1 000	380	100
1 010	380	101
1 050	200	105
1 080	380	108
1 100	380	110
1 140	380	114
1 150	380	115
1 200	200	120
1 210	380	121
1 240	380	124

Length (mm)	Width (mm)	No of Teeth
1 250	380	125
1 300	380	130
1 320	380	132
1 350	380	135
1 390	380	139
1 400	380	140
1 420	380	142
1 440	380	144
1 450	380	145
1 460	380	146
1 500	380	150
1 560	380	156
1 600	200	160
1 610	200	161
1 700	200	170
1 750	200	175
1 780	200	178
1 800	200	180
1 880	200	188
1 960	200	196
2 250	200	225

TIMING BELTS

SELF TRACKING

FLST BELTS

WIDE BELTS

ENDLESS BELTS

FINISHING

INFORMATION

ENDLESS BELTS

GATES SYNCHRO-POWER® - TRULY ENDLESS (CAST) BELTS

TIMING BELTS

SELF TRACKING

FLAT BELTS

WIDE BELTS

ENDLESS BELTS

FINISHING

INFORMATION

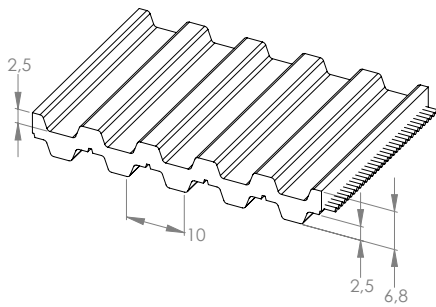

Pitch	10 mm
Standard Color	Blue
Width Tolerance complete Sleeve	± 3.0 mm
Minimum Number of Pulley Teeth z_{min}	14
Minimum Pulley Diameter	44.56 mm
Minimum Back Bend Diameter	44.56 mm
FDA/EU Approval	No

Standard Width (mm)	10	12	16	20	25	32	50
Tensile Strength (Average Value) F_{Break} (N)							
Steel	3 350	4 195	5 910	7 585	9 700	12 580	20 190
Allowable Belt Force F_{1all} (N)							
Steel	763	916	1 221	1 527	1 909	2 443	3 817
Allowable Effective Force F_{eall} (N)							
(Minimum 15 teeth are in mesh)	676	811	1 082	1 352	1 690	2 163	3 380
Specific Belt Stiffness c_{sp} (N)							
Steel	190 850	229 020	305 360	381 700	477 125	610 720	954 250

DT10

Length (mm)	Width (mm)	No of Teeth
600	380	60
630	200	63
660	200	66
700	380	70
750	380	75
800	380	80
840	200	84
900	380	90
980	200	98
1 000	380	100
1 100	380	110
1 200	380	120
1 210	200	121
1 300	380	130
1 320	200	132
1 420	200	142
1 600	380	160
1 610	200	161
1 700	380	170
1 880	200	188

TIMING BELTS

SELF TRACKING

FLST BELTS

WIDE BELTS

ENDLESS BELTS

FINISHING

INFORMATION

ENDLESS BELTS

GATES SYNCHRO-POWER® - TRULY ENDLESS (CAST) BELTS

TIMING BELTS

SELF TRACKING

FLAT BELTS

WIDE BELTS

ENDLESS BELTS

FINISHING

INFORMATION

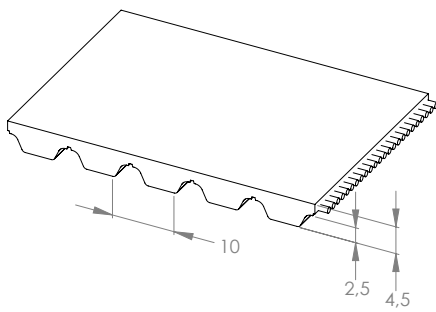

Pitch	10 mm
Standard Color	Blue
Width Tolerance complete Sleeve	± 3.0 mm
Minimum Number of Pulley Teeth z_{min}	15
Minimum Pulley Diameter	47.75 mm
Minimum Back Bend Diameter	120 mm
FDA/EU Approval	No

Standard Width (mm)	10	12	16	20	25	32	50	75
Tensile Strength (Average Value) F_{Break} (N)								
Steel	4 750	5 700	8 565	10 485	14 305	18 100	29 485	45 575
Allowable Belt Force F_{Tall} (N)								
Steel	1 496	1 796	2 394	2 993	3 741	4 788	7 482	11 223
Allowable Effective Force F_{eall} (N)								
(Minimum 15 teeth are in mesh)	1 032	1 238	1 651	2 064	2 580	3 302	5 160	7 740
Specific Belt Stiffness c_{sp} (N)								

AT10

Length (mm)	Width (mm)	No. of Teeth
500	380	50
560	380	56
610	380	61
660	380	66
700	380	70
730	380	73
780	380	78
800	380	80
840	380	84
890	380	89
920	380	92
960	380	96
980	380	98
1 010	380	101
1 050	380	105
1 080	380	108
1 100	200	110

Length (mm)	Width (mm)	No. of Teeth
1 150	380	115
1 200	380	120
1 210	380	121
1 250	380	125
1 280	200	128
1 320	380	132
1 350	200	135
1 360	200	136
1 400	380	140
1 420	200	142
1 480	200	148
1 500	380	150
1 600	200	160
1 700	200	170
1 800	200	180
1 860	200	186
1 940	200	194

TIMING BELTS

SELF TRACKING

FLST BELTS

WIDE BELTS

ENDLESS BELTS

FINISHING

INFORMATION

ENDLESS BELTS

TRULY ENDLESS FLEX BELTS

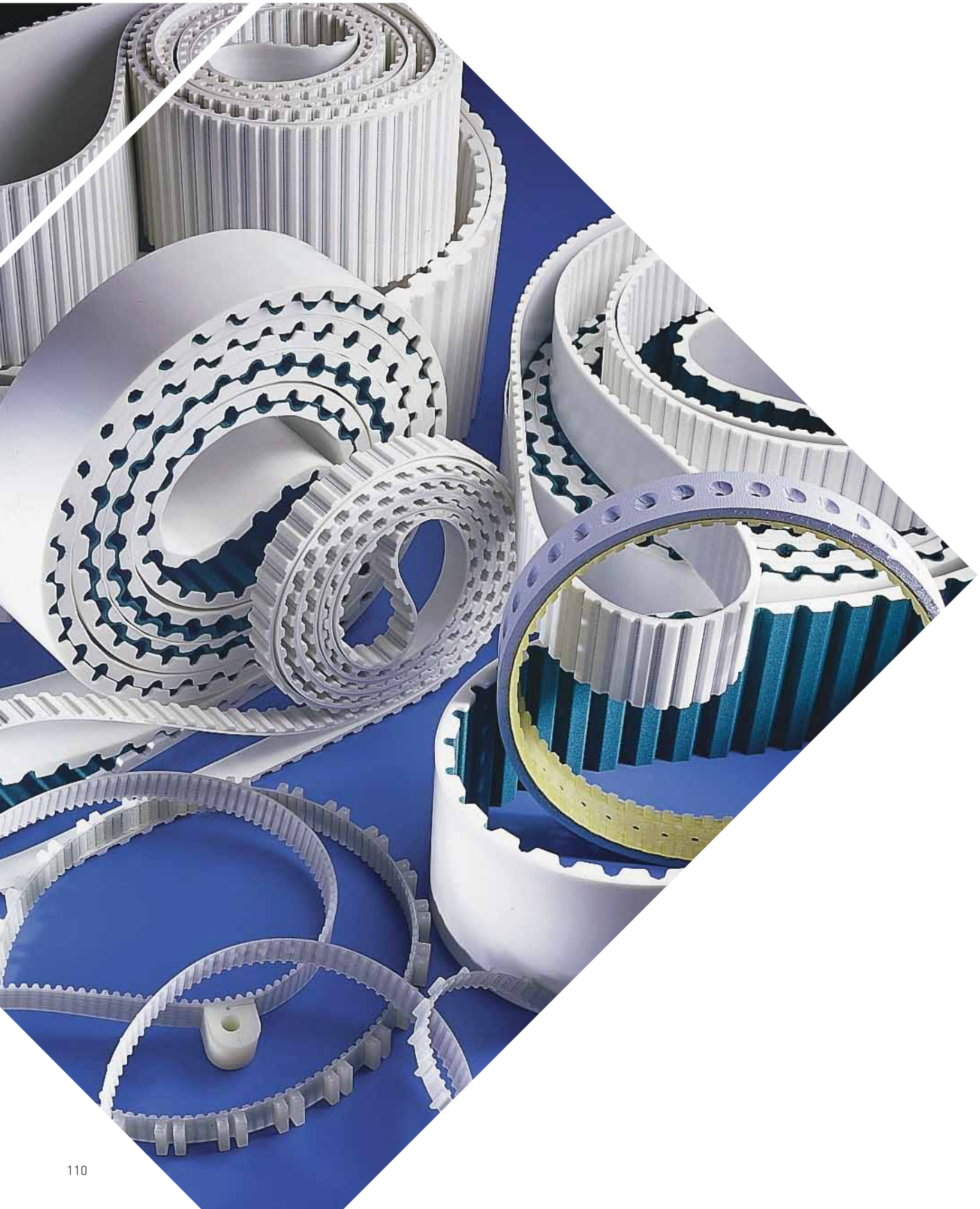

Flex Belts are truly endless extruded with helically wound steel cords in different sizes, constructions and pitches.

ATTRIBUTES

- › Extruded, thermoplastic polyurethane construction
- › High performance and power transmission based on truly endless cords
- › Synchronous tracking

APPLICATIONS

- › Wood processing industry
- › Textile industry
- › Conveying machines
- › Foiling machine
- › Power transmission
- › Highly stressed conveying applications

PROCESSING OPTIONS

- › Backings *Further information on page 124*
- › Special processing *Further information on page 146*

FABRICATION CAPABILITIES

- › Pitches H / T5 / T10 / T20 / AT5 / AT10 / AT20 / ATL10 / ATL20
HTD®5 / HTD®8 / HTD®14
- › Widths 10 mm up to 100 mm
- › Lengths 1 550 mm up to 23 500 mm
- › Polyurethane 92 Shore A (standard)
- › Tension members Steel cord (standard)
- › Polyamide Fabric Polyamide fabric on tooth side (NT)

Further constructions are available on request.

ENDLESS BELTS

H

TRULY ENDLESS FLEX BELTS

TIMING BELTS

SELF TRACKING

FLAT BELTS

WIDE BELTS

ENDLESS BELTS

FINISHING

INFORMATION

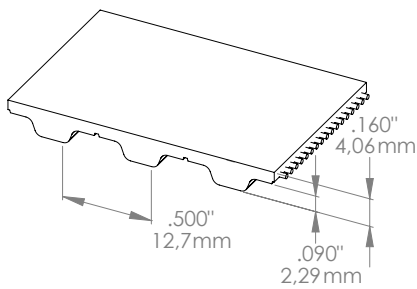

Pitch	0.500"
Standard Color	White
Width Tolerance up to 2" Width	± 0.020" / 0.51 mm
> 2" Width	± 0.030" / 0.76 mm
Minimum Number of Pulley Teeth z_{min}	14
Minimum Pulley Diameter	2.23" / 56.64 mm
Minimum Back Bend Diameter	3.125" / 79.4 mm
Standard Lengths	1 562.1 mm up to 23 495 mm

Standard Width (Inch)	0.50	0.75	1	1.5	2	3	4
Tensile Strength (Average Value) F_{Break} (N)							
Steel	3 360	5 040	7 140	10 920	14 700	22 260	29 820
Allowable Belt Force F_{1all} (N)							
Steel	898	1 347	1 909	2 919	3 929	5 950	7 971
Allowable Effective Force F_{eall} (N)							
(Minimum 15 teeth are in mesh)	980	1 470	1 960	2 940	3 920	5 880	7 840
Specific Belt Mass m_{sp} (kg/m/mm)	0.0039						
Specific Belt Stiffness c_{sp} (N)							
Steel	224 529	336 794	477 125	729 721	982 316	1 487 507	1 992 699

T5

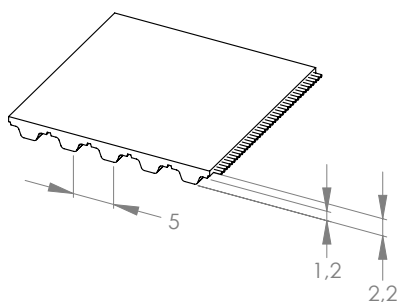

Pitch	5 mm
Standard Color	White
Width Tolerance up to 50 mm Width	± 0.5 mm
> 50 mm Width	± 0.75 mm
Minimum Number of Pulley Teeth z_{min}	10
Minimum Pulley Diameter	15,91 mm
Minimum Back Bend Diameter	30 mm
Standard Lengths	1 550 mm up to 15 000 mm

Standard Width (mm)	10	16	25	32	50	75	100
Tensile Strength (Average Value) F_{Break} (N)							
Steel	1 250	2 000	3 375	4 250	6 875	10 375	13 875
Allowable Belt Force F_{1all} (N)							
Steel	311	498	840	1 058	1 711	2 582	3 453
Allowable Effective Force F_{eall} (N)							
(Minimum 15 teeth are in mesh)	356	570	890	1 139	1 780	2 670	3 560
Specific Belt Mass m_{sp} (kg/m/mm)							
Steel	0.0022						
Specific Belt Stiffness c_{sp} (N)							
Steel	77 778	124 444	210 000	264 444	427 778	645 556	863 333

ENDLESS BELTS

T10

TRULY ENDLESS FLEX BELTS

TIMING BELTS

SELF-TRACKING

FLAT BELTS

WIDE BELTS

ENDLESS BELTS

FINISHING

INFORMATION

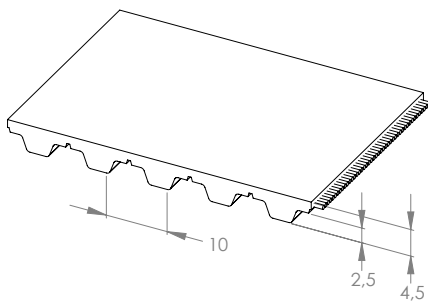

Pitch	10 mm
Standard Color	White
Width Tolerance up to 50 mm Width	± 0.5 mm
> 50 mm Width	± 0.75 mm
Minimum Number of Pulley Teeth z_{min}	14
Minimum Pulley Diameter	44.56 mm
Minimum Back Bend Diameter	80 mm
Standard Lengths	1 550 mm up to 23 500 mm

Standard Width (mm)	16	25	32	50	75	100
Tensile Strength (Average Value) F_{Break} (N)						
Steel	4 200	7 140	9 240	14 700	22 260	29 820
Allowable Belt Force F_{Tall} (N)						
Steel	1 123	1 909	2 470	3 929	5 950	7 971
Allowable Effective Force F_{eall} (N)						
(Minimum 15 teeth are in mesh)	1 082	1 690	2 163	3 380	5 070	6 760
Specific Belt Mass m_{sp} (kg/m/mm)						
	0.0043					
Specific Belt Stiffness c_{sp} (N)						
Steel	280 662	477 125	617 456	982 316	1 487 507	1 992 699

T20

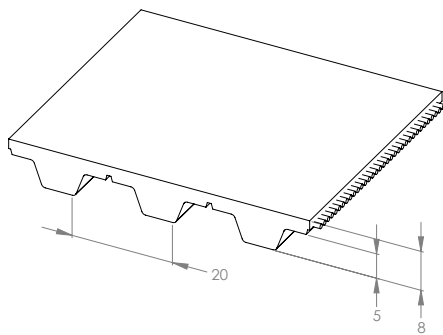

Pitch	20 mm
Standard Color	White
Width Tolerance	± 1.0 mm
Minimum Number of Pulley Teeth z_{min}	15
Minimum Pulley Diameter	95.49mm
Minimum Back Bend Diameter	120 mm
Standard Lengths	1 550 mm up to 23 500 mm

Standard Width (mm)	32	50	75	100
Tensile Strength (Average Value) F_{Break} (N)				
Steel	18 050	29 450	44 650	59 850
Allowable Belt Force F_{1all} (N)				
Steel	4 739	7 731	11 722	15 712
Allowable Effective Force F_{eall} (N)				
(Minimum 15 teeth are in mesh)	4 045	6 320	9 480	12 640
Specific Belt Mass m_{sp} (kg/m/mm)				
Steel	0.0073			
Specific Belt Stiffness c_{sp} (N)				
Steel	1 184 650	1 932 850	2 930 450	3 928 050

TIMING BELTS

SELF TRACKING

FLST BELTS

WIDE BELTS

ENDLESS BELTS

FINISHING

INFORMATION

ENDLESS BELTS

AT5

TRULY ENDLESS FLEX BELTS

TIMING BELTS

SELF-TRACKING

FLAT BELTS

WIDE BELTS

ENDLESS BELTS

FINISHING

INFORMATION

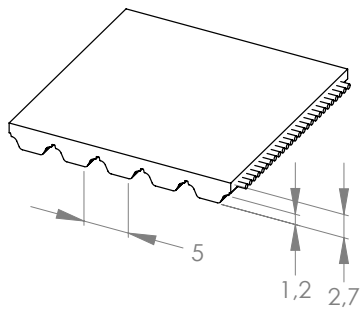

Pitch	5 mm
Standard Color	White
Width Tolerance up to 50 mm Width	± 0.5 mm
> 50 mm Width	± 0.75 mm
Minimum Number of Pulley Teeth z_{min}	15
Minimum Pulley Diameter	23.87 mm
Minimum Back Bend Diameter	60 mm
Standard Lengths	1 550 mm up to 14 900 mm

Standard Width (mm)	10	16	25	32	50	75	100
Tensile Strength (Average Value) F_{Break} (N)							
Steel	2 565	4 275	7 125	9 120	14 535	21 945	29 355
Allowable Belt Force F_{Tall} (N)							
Steel	634	1 056	1 761	2 253	3 591	5 422	7 253
Allowable Effective Force F_{eall} (N)							
(Minimum 15 teeth are in mesh)	516	826	1 290	1 651	2 580	3 870	5 160
Specific Belt Mass m_{sp} (kg/m/mm)							
	0.0032						
Specific Belt Stiffness c_{sp} (N)							
Steel	158 445	264 075	440 125	563 360	897 855	1 355 585	1 813 315

AT10

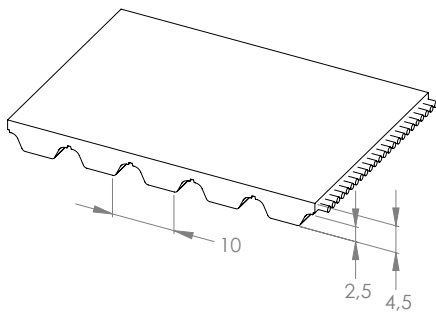

Pitch	10 mm
Standard Color	White
Width Tolerance up to 50 mm Width	± 0.75 mm
> 50 mm Width	± 1.0 mm
Minimum Number of Pulley Teeth z_{min}	15
Minimum Pulley Diameter	47.75 mm
Minimum Back Bend Diameter	120 mm
Standard Lengths	1 550 up to 23 500 mm

Standard Width (mm)	25	32	50	75	100
Tensile Strength (Average Value) F_{Break} (N)					
Steel	14 250	18 050	29 450	44 650	59 850
Allowable Belt Force F_{1all} (N)					
Steel	3 741	4 739	7 731	11 722	15 712
Allowable Effective Force F_{eall} (N)					
(Minimum 15 teeth are in mesh)	2 580	3 302	5 160	7 740	10 320
Specific Belt Mass m_{sp} (kg/m/mm)					
Steel	0.0056				
Specific Belt Stiffness c_{sp} (N)					
Steel	935 250	1 184 650	1 932 850	2 930 450	3 928 050

TIMING BELTS

SELF TRACKING

FLST BELTS

WIDE BELTS

ENDLESS BELTS

FINISHING

INFORMATION

ENDLESS BELTS

ATL10

TRULY ENDLESS FLEX BELTS

TIMING BELTS

SELF TRACKING

FLAT BELTS

WIDE BELTS

ENDLESS BELTS

FINISHING

INFORMATION

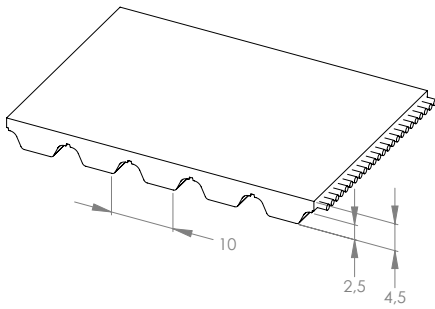

Pitch	10 mm
Standard Color	White
Width Tolerance up to 50 mm Width	± 1.0 mm
> 50 mm Width	± 1.5 mm
Minimum Number of Pulley Teeth z_{min}	25
Minimum Pulley Diameter	79.60 mm
Minimum Back Bend Diameter	150 mm
Standard Lengths	1 550 mm up to 23 500 mm

Standard Width (mm)	10	16	25	32	50
Tensile Strength (Average Value) F_{Break} (N)					
Steel	24 220	31 140	50 170	76 120	102 070
Allowable Belt Force F_{Tall} (N)					
Steel	5 860	7 534	12 139	18 417	24 696
Allowable Effective Force F_{eall} (N)					
(Minimum 15 teeth are in mesh)	2 580	3 302	5 160	7 740	10 320
Specific Belt Mass m_{sp} (kg/m/mm)	0.0067				
Specific Belt Stiffness c_{sp} (N)					
Steel	1 465 000	1 883 571	3 034 643	4 604 286	6 173 929

AT20

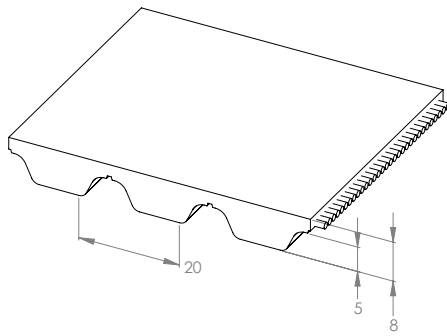

Pitch	20 mm
Standard Color	White
Width Tolerance up to 50 mm Width	± 1.0 mm
> 50 mm Width	± 1.5 mm
Minimum Number of Pulley Teeth z_{min}	18
Minimum Pulley Diameter	114.59 mm
Minimum Back Bend Diameter	180 mm
Standard Lengths	1 550 mm up to 23 500 mm

Standard Width (mm)	32	50	75	100
Tensile Strength (Average Value) F_{Break} (N)				
Steel	31 140	50 170	76 120	102 070
Allowable Belt Force F_{1all} (N)				
Steel	7 534	12 139	18 417	24 696
Allowable Effective Force F_{eall} (N)				
(Minimum 15 teeth are in mesh)	6 950	10 860	16 290	21 720
Specific Belt Mass m_{sp} (kg/m/mm)				
Steel	0.0099			
Specific Belt Stiffness c_{sp} (N)				
Steel	1 883 571	3 034 643	4 604 286	6 173 929

TIMING BELTS

SELF TRACKING

FLST BELTS

WIDE BELTS

ENDLESS BELTS

FINISHING

INFORMATION

ENDLESS BELTS

ATL20

TRULY ENDLESS FLEX BELTS

TIMING BELTS

SELF-TRACKING

FLAT BELTS

WIDE BELTS

ENDLESS BELTS

FINISHING

INFORMATION

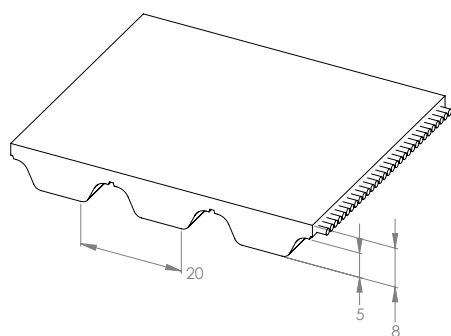

Pitch	20 mm
Standard Color	White
Width Tolerance	± 2.0 mm
Minimum Number of Pulley Teeth z_{\min}	30
Minimum Pulley Diameter	190.98 mm
Minimum Back Bend Diameter	250 mm
Standard Lengths	1 550 mm up to 23 500 mm

Standard Width (mm)	32	50	75	100
Tensile Strength (Average Value) F_{Break} (N)				
Steel	41 600	70 400	105 600	144 000
Allowable Belt Force F_{Tall} (N)				
Steel	9 106	15 410	23 115	31 520
Allowable Effective Force F_{eall} (N)				
(Minimum 15 teeth are in mesh)	6 950	10 860	16 290	21 720
Specific Belt Mass m_{sp} (kg/m/mm)	0.0108			
Specific Belt Stiffness c_{sp} (N)				
Steel	2 276 477	3 852 500	5 778 750	7 880 114

HTD[®]5

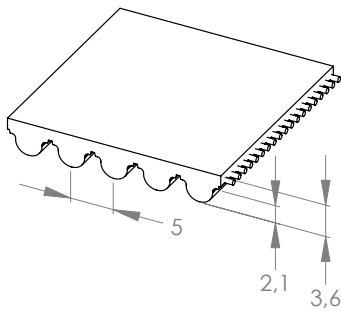

Pitch	5 mm
Standard Color	White
Width Tolerance up to 50 mm Width	± 0.5 mm
> 50 mm Width	± 0.75 mm
Minimum Number of Pulley Teeth z_{min}	14
Minimum Pulley Diameter	22.28 mm
Minimum Back Bend Diameter	60 mm
Standard Lengths	1 550 mm up to 14 900 mm

Standard Width (mm)	25	50	100
Tensile Strength (Average Value) F_{Break} (N)			
Steel	7 125	14 535	29 355
Allowable Belt Force F_{1all} (N)			
Steel	1 761	3 591	7 253
Allowable Effective Force F_{eall} (N)			
(Minimum 15 teeth are in mesh)	1 020	2 040	4 080
Specific Belt Mass m_{sp} (kg/m/mm)			
Steel	0.0041		
Specific Belt Stiffness c_{sp} (N)			
Steel	440 125	897 855	1 813 315

TIMING BELTS

SELF TRACKING

FLST BELTS

WIDE BELTS

ENDLESS BELTS

FINISHING

INFORMATION

ENDLESS BELTS

HTD[®]8

TRULY ENDLESS FLEX BELTS

TIMING BELTS

SELF TRACKING

FLAT BELTS

WIDE BELTS

ENDLESS BELTS

FINISHING

INFORMATION

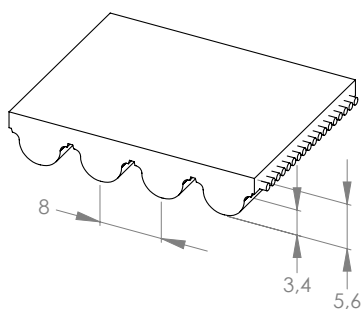

Pitch	8 mm
Standard Color	White
Width Tolerance up to 50 mm Width	± 0.75 mm
> 50 mm Width	± 1.0 mm
Minimum Number of Pulley Teeth z_{min}	20
Minimum Pulley Diameter	50.93 mm
Minimum Back Bend Diameter	120 mm
Standard Lengths	1 552 mm up to 23 496 mm

Standard Width (mm)	25	30	50	100
Tensile Strength (Average Value) F_{Break} (N)				
Steel	14 250	17 100	29 450	59 850
Allowable Belt Force F_{Tall} (N)				
Steel	3 741	4 489	7 731	15 712
Allowable Effective Force F_{eall} (N)				
(mid. 15 Zähle im Eigriff)	1 870	2 244	3 740	7 480
Specific Belt Mass m_{sp} (kg/m/mm)	0.0059			
Specific Belt Stiffness c_{sp} (N)				
Steel	935 250	1 122 300	1 932 850	3 928 050

HTD®14

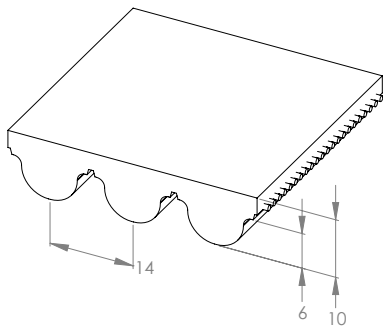

Pitch	14 mm
Standard Color	White
Width Tolerance up to 50 mm Width > 50 mm Width	± 1.0 mm ± 1.5 mm
Minimum Number of Pulley Teeth z_{min}	28
Minimum Pulley Diameter	124.78 mm
Minimum Back Bend Diameter	200 mm
Standard Lengths	1 554 up to 23 492 mm

Standard Width (mm)	25	40	55	85	100
Tensile Strength (Average Value) F_{Break} (N)					
Steel	20 760	34 600	48 440	74 390	88 230
Allowable Belt Force F_{1all} (N)					
Steel	5 156	8 593	12 031	18 476	21 913
Allowable Effective Force F_{eall} (N)					
(Minimum 15 teeth are in mesh)	3 430	5 488	7 546	11 662	13 720
Specific Belt Mass m_{sp} (kg/m/mm)					
Steel	0.0107				
Specific Belt Stiffness c_{sp} (N)					
Steel	1 289 000	2 148 333	3 007 667	4 618 917	5 478 250

TIMING BELTS

SELF TRACKING

FLST BELTS

WIDE BELTS

ENDLESS BELTS

FINISHING

INFORMATION

FINISHING

COATED BELTS



Most belt types can be modified with a coating to achieve a desired coefficient of friction, abrasion resistance or thickness. Gates offers more than 20 backings in categories such as polyurethane, rubber, foam, PVC and special backings to meet your requirements.

All backings can be modified mechanically on request. Gates customizes belts especially according to your requirements.

PROCESSING OPTIONS

- › Grinding
- › Milling
- › Sandwich Belts
- › Grooves
- › Holes

Further information on page 146

ATTRIBUTES

- › Low vibration and quiet operation
- › Reduced noise characteristics
- › Adaption of friction

APPLICATIONS

- › Metal stamping industry
- › Feeding and pulling applications
- › Paper handling
- › Glass conveying
- › Food industry
- › Cardboard conveying

FABRICATION CAPABILITIES

- | | |
|------------------------------------|---------------|
| › Minimum width | 10 mm |
| › Maximum width | 450 mm |
| › Minimum length | 480 mm |
| › Maximum length / welding process | No limitation |
| › Maximum length / gluing process | No limitation |

Further information regarding backings, thicknesses or special dimensions is available on request.

POLYURETHANE (PU) BACKINGS

TIMING BELTS

SELF TRACKING

FLAT BELTS

WIDE BELTS

ENDLESS BELTS

FINISHING

INFORMATION

Polyurethane is the most abrasion-proof, resilient and durable backing. Polyurethane backings are available in different thicknesses and hardnesses and are applied by welding process on to the belt.

ATTRIBUTES

- › Excellent friction
- › Good abrasion resistance
- › Good durability vs. chemicals
- › Excellent durability vs. oil and fat
- › Available with FDA / EU food approval

APPLICATIONS

- › Stone processing industry
- › Wood processing industry
- › Glass processing industry
- › Card sheet processing industry
- › Cardboard transport
- › Packaging industry
- › Feeding and pulling applications
- › Ascending conveyor

Material	Color	Hardness	Material Thickness	Minimum Ø / Ø Factor	Approval	Backing
PU	CLEAR	75 Shore A	2 mm / 3 mm *	x 30		75 Shore A Polyurethane Clear 
PU	CLEAR	85 Shore A	2 mm / 3 mm *	x 30	FDA / EU	85 Shore A Polyurethane Clear 
PU	CLEAR	92 Shore A	2 mm *	x 30		92 Shore A Polyurethane Clear 
PU	CLEAR	75 Shore A	5 mm	Ø 120 mm		Glass Backing 
PU	CLEAR	85 Shore A	3 mm	Ø 90 mm		Ridge Top 
PU	CLEAR	85 Shore A	1 mm / 2 mm *	x 30		HV Foil 
PU	CLEAR	85 Shore A 92 Shore A	2.7 mm	Ø 75 mm		Fine Glass Backing 

* Several layers can be welded together or grinded for other thicknesses.

TIMING BELTS

SELF TRACKING

FLAT BELTS

WIDE BELTS

ENDLESS BELTS

FINISHING

INFORMATION

FINISHING

RUBBER BACKINGS

TIMING BELTS

SELF TRACKING

FLAT BELTS

WIDE BELTS

ENDLESS BELTS

FINISHING

INFORMATION







Rubber backings are commonly used in industries such as wood processing, glass processing and ceramics industry based on their high coefficient of friction and temperature resistance as well as good abrasion resistance. Rubber backings are applied by adhesive bonding.

ATTRIBUTES

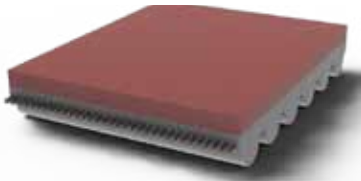
- › Excellent friction
- › Good abrasion resistance
- › Good durability vs. temperature and resistance to atmospheric conditions
- › Flexibility at low temperatures
- › Available with FDA Approval

APPLICATIONS

- › Wood processing industry
- › Metal stamping industry
- › Paper processing industry
- › Textile processing industry
- › Packaging industry
- › Feeding and pulling applications
- › Pharmaceutical / cosmetic industry

Material	Color	Hardness	Material Thickness	Minimum Ø / Ø Factor	Approval	Backing
NATURAL RUBBER	RED	38 Shore A	1,6 mm up to 10 mm *	x 20		Linatex® 
NATURAL RUBBER	WHITE	38 Shore A	3 mm / 5 mm / 8 mm *	x 20	FDA	Linaplus FG™ 
NATURAL RUBBER	BEIGE	40 Shore A	3 mm / 6 mm *	x 20		Tan Natural Rubber 
NATURAL RUBBER	BLACK	65 Shore A	3 mm / 5 mm / 6 mm *	x 25		Nitrile Rubber 
NATURAL RUBBER	ORANGE	55 Shore A	3 mm / 8 mm *	x 20		Linatrilite® 
NATURAL RUBBER	YELLOW	38 Shore A	2 mm / 4 mm *	x 20		RP400 

* Several layers can be glued together or grinded for other thicknesses.

TIMING BELTS

SELF TRACKING

FLAT BELTS

WIDE BELTS

ENDLESS BELTS

FINISHING

INFORMATION

FINISHING

FOAM BACKINGS

TIMING BELTS

SELF TRACKING

FLAT BELTS

WIDE BELTS

ENDLESS BELTS

FINISHING

INFORMATION

Foam backings are commonly used in glass, paper, textile and wood processing industries due to their flexibility. Foam backings are applied by adhesive bonding.

ATTRIBUTES

- › Excellent compressibility
- › Good abrasion resistance
- › Excellent coefficient of friction
- › Good durability vs. chemicals
- › Good durability vs. oil and fat

APPLICATIONS

- › Paper processing industry
- › Foil processing industry
- › Wood processing industry
- › Glass processing industry
- › Labeling machines
- › Feeding and pulling applications
- › Vacuum applications
- › Cleaning / bottling applications

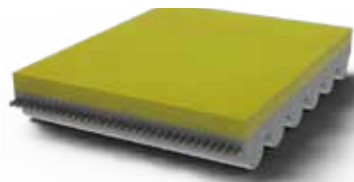
Material	Color	Hardness / Density	Material Thickness	Minimum Ø / Ø Factor	ATTRIBUTES	Backing
POLYURETHANE	YELLOW	55 Shore A	2 mm up to 8 mm *	x 30		<p>HD Yellow</p> 
FOAMED POLYURETHANE	YELLOW	160 kg/m ³	12 mm *	x 15		<p>Sylomer® Yellow</p> 

Material	Color	Hardness / Density	Material Thickness	Minimum Ø / Ø Factor	Attributes	Backing
FOAMED POLYURETHANE	BLUE	220 kg/m ³	12 mm / 25 mm *	x 15		<p>Sylomer® Blue</p> 
FOAMED POLYURETHANE	GREEN	300 kg / m	6 mm up to 25 mm *	x 15		<p>Sylomer® Green</p> 
FOAMED POLYURETHANE	BROWN	400 kg / m	6 mm / 12 mm / 25 mm *	x 15		<p>Sylomer® Brown</p> 
FOAMED POLYURETHANE	RED	500 kg / m	6 mm / 12 mm / 25 mm *	x 15		<p>Sylomer® red</p> 
CELLULAR RUBBER	BLACK	150- 200 kg/m ³	3 mm / 5 mm / 10 mm *	x 15		<p>Neoprene</p> 
NATURAL POLYURETHANE FOAM	BEIGE / YELLOW	400 kg/m ³	3 mm up to 8 mm *	x 15	High Flexible	<p>Natural</p> 

* Several layers can be glued together or grinded for other thicknesses.

POLYVENYLCHLORID (PVC) BACKINGS

TIMING BELTS

SELF TRACKING

FLAT BELTS

WIDE BELTS

ENDLESS BELTS

FINISHING

INFORMATION



Due to various backing characteristics, Polyvinylchlorid (PVC) backings are commonly used in glass processing, wood processing, ceramic and packaging industries. Various FDA/EU approvals for different PVC backings allow applications in sectors such as food and where good hygiene is required. PVC backings are applied by adhesive bonding.



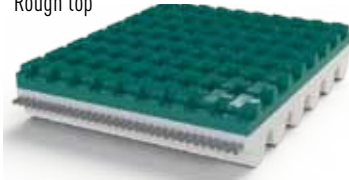

ATTRIBUTES

- › Good durability vs. acids and chemicals
- › Good resistance to atmospheric conditions
- › Very adhesive
- › Available with FDA/EU approval
- › Available with various surface textures such as rough top and saw tooth

APPLICATIONS

- › Wood processing industry
- › Glass processing industry
- › Stone processing industry
- › Paper processing industry
- › Labeling industry
- › Packaging industry
- › Pharmaceutical / cosmetic industry

Material	Color	Hardness	Material Thickness	Minimum Ø / Ø Factor	Approval	Backing
PVC	GREEN	46 Shore A	4,8 mm	90 mm		Rough top 
PVC	WHITE	65 Shore A	1,2 mm	25 mm	FDA / EU	Small Pebble Structure 

Material	Color	Hardness	Material Thickness	Minimum Ø / Ø Factor	Approval	Backing
PVC	WHITE	35 Shore A	6 mm	40 mm	FDA/EU	<p>Large Pebble Structure</p> 
PVC	WHITE	70 Shore A	4,5 mm	90 mm	FDA	<p>PVC Herringbone</p> 
PVC	WHITE	40 Shore A	2,5 mm	90 mm	FDA/EU	<p>PVC Saw Tooth</p> 
PVC	WHITE	65 Shore A	0,7 mm	50 mm	FDA	<p>PVC Waffle Structure</p> 
PVC	BLUE	60 Shore A	1 mm / 2 mm	40 mm		<p>PVC Blue</p> 
PVC	WHITE	65 Shore A	2 mm	40 mm	FDA EU	<p>PVC White</p> 

TIMING BELTS

SELF TRACKING

FLAT BELTS

WIDE BELTS

ENDLESS BELTS

FINISHING

INFORMATION

SPECIAL BACKINGS - SPECIAL FABRIC

In addition to our standard backing types, we offer special backings, such as Novo Fleece and Chrome Leather. Both backings are applied by adhesive bonding.

NOVO FLEECE

- | | |
|-----------------------|---|
| > Material: | Polyester |
| > Color: | Anthracite |
| > Hardness: | Incapable of measurement |
| > Material Thickness: | 1,2 mm |
| > Mindestdurchmesser: | Ø 25 mm |
| > Attributes: | Suited for high temperature ranges
Good durability vs. oil and fat |
| > Applications: | General conveying applications, glass processing |



CHROME LEATHER

- | | |
|-----------------------|---|
| > Material: | Leather |
| > Color: | Grey |
| > Hardness: | 65 Shore A |
| > Material Thickness: | 2 mm / 3 mm |
| > Mindestdurchmesser: | Ø 90 mm |
| > Attributes: | Excellent coefficient of friction
Good abrasion resistance
Excellent oil resistance |
| > Applications: | General conveying applications |



POLYAMIDE FABRIC

Polyamide fabric on tooth and/or back reduces the coefficient of friction and provides smooth and enhanced operation characteristics for custom designed applications. Polyamide fabric is added to the belt during the extrusion process.

ATTRIBUTES

- > low coefficient of friction
- > High wear resistance
- > Good sliding attributes
- > Low noise operation
- > Good durability vs. oil and fat

APPLICATIONS

- > Accumulating conveyor
- > Sliding applications

POLYAMIDE FABRIC ON TOOTH SIDE

- › Code: NT / Nylon® Tooth
- › Color: Green

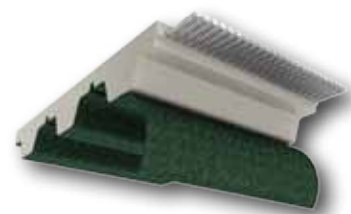

POLYAMIDE FABRIC ON BACK

- › Code: NB / Nylon® Back
- › Color: Green

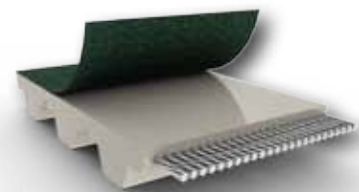

POLYAMIDE FABRIC ON TOOTH AND BACK

- › Code: NTB / Nylon® Tooth and Back
- › Color: Green

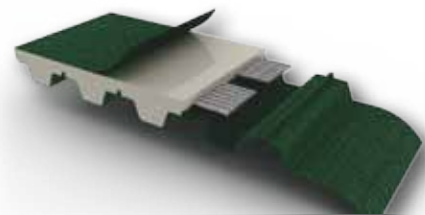

SPECIAL FABRIC

ECO Fabric offers both, antistatic features as well as an extremely low coefficient of friction. Depending on its application area ECO also provides an extended service life in comparison to the standard polyamide fabric. The special antistatic fabric is available for standard pitches such as T5 / T10 / AT5 / AT10.

ECO FABRIC ON TOOTH AND BACK

- › Color: Anthracite

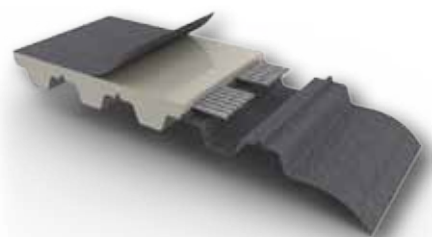

Further backings, thicknesses and special dimensions are available on request.

FINISHING

OVERVIEW BACKINGS

TIMING BELTS

SELF TRACKING

FLAT BELTS

WIDE BELTS

ENDLESS BELTS

FINISHING

INFORMATION

Backing	Code	Hardness (Shore A) Density (kg/m ³)	Material Thickness (mm)	Abrasion Resistance	Oil Resistance	Attributes
Polyurethane (PU)						
Polyurethane 75 Shore A	U32 / U33	75 Shore A	2 / 3	1	1	
Polyurethane 85 Shore A	U22 / U23	85 Shore A	2 / 3	1	1	FDA / EU
Polyurethane 92 Shore A	U12	92 Shore A	2	1	1	
Glass Backing	G32	75 Shore A	5	1	1	
Ridge Top	G21	85 Shore A	3	1	1	
HV Foil	U41 / U42	85 Shore A	1 / 2	1	1	
Fine Glass Backing 85 Shore A	G53	85 Shore A	2.7	1	1	
Fine Glass Backing 92 Shore A	G52	92 Shore A	2.7	1	1	
Rubber						
Linatex®	L	38 Shore A	1.6 up to 10	2	4	
Linaplus FG™	LP	38 Shore A	3 / 5 / 8	2	4	FDA
Tan Natural Rubber	LT	40 Shore A	3 / 6	2	4	
Nitrile Rubber	LB	65 Shore A	3 / 5 / 6	2	1	
Linatrite®	NL	55 Shore A	3 / 8	2	2	
RP400 / Racloprema	RP2 / RP4	38 Shore A	2 / 4	1	2	
Schaum						
HD Yellow	FUY	55 Shore A	2 up to 8	3	1	
Sylomer® Yellow	FY	160 kg/m ³	12	4	1	
Sylomer® Blue	FB	220 kg/m ³	12 / 25	4	1	
Sylomer® Green	FG	300 kg/m ³	6 / 12 / 25	3	1	
Sylomer® Brown	FN	400 kg/m ³	6 / 12 / 25	3	1	
Sylomer® Red	FR	500 kg/m ³	6 / 12 / 25	3	1	
Neoprene	NF	150-200 kg/m ³	3 / 5 / 10	4	3	
Natural	FC	400 kg/m ³	3 up to 8	3	1	

Backing	Code	Hardness (Shore A) Density (kg/m ³)	Material Thickness (mm)	Abriebfestigkeit*	Ölbeständigkeit*	Sonstige ATTRIBUTES
PVC						
Rough Top	RT	46 Shore A	4.8	3	4	
Small Pebble	SPT	65 Shore A	1.2	3	4	FDA / EU
Large Pebble	LPT	35 Shore A	6	3	4	FDA / EU
PVC Herringbone	PH	70 Shore A	4.5	3	4	FDA
PVC Saw Tooth	ST	40 Shore A	2.5	2	3	FDA / EU
PVC Waffle Structure	PTW	65 Shore A	0.7	2	3	FDA
PVC Blue	PB	60 Shore A	1 / 2	3	4	
PVC White	PW	65 Shore A	2	3	4	FDA / EU
Special Backings						
Novo Fleece	NV	Not specified	1.2	3	2	
Chrome Leather	Not specified	65 Shore A	2 / 3	2	1	
Polyamide Fabric						
Polyamide Fabric Tooth Side	NT	Not specified	Not specified	2	1	
Polyamid Fabric Back	NB	Not specified	Not specified	2	1	
Polyamid Fabric Tooth and Back	NTB	Not specified	Not specified	2	1	
ECO Fabric Tooth and Back	ECO	Not specified	Not specified	1	1	Antistatic

Stave for abrasion resistance / oil resistance:

1 – very good 2 – good 3 – satisfactory 4 – adequate 5 – poor 6 – inadequate

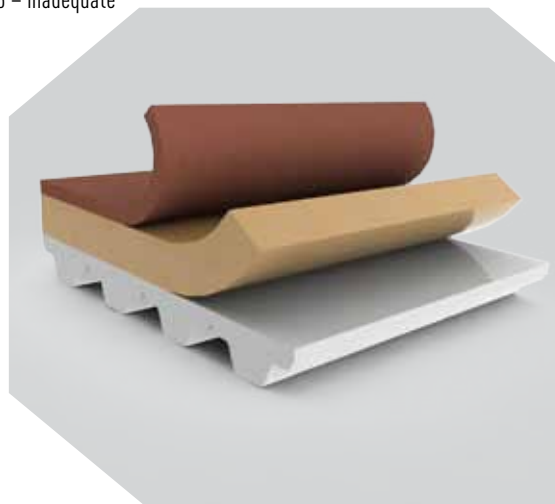

FINISHING

PROFILED BELTS

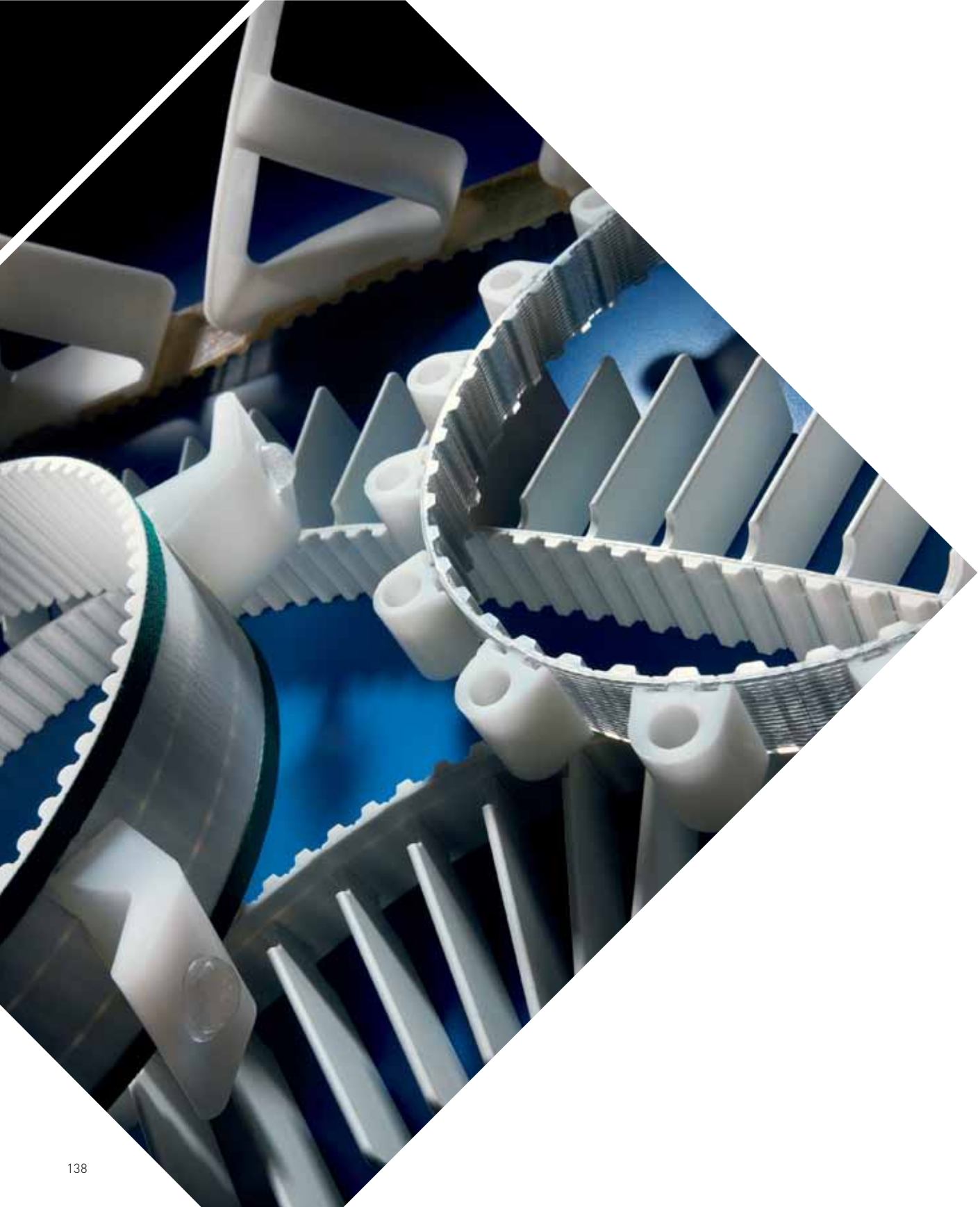



Gates Timing Belts can be customized with welded profiles to meet specific application requirements. The molded profiles are made of tough polyurethane and become an integral part of the belt through thermal bonding. Profiles can be manufactured in nearly any shape and construction.

Our timing belts with welded profiles are optimal for applications in packaging, general conveying and other automation equipment applications.

Choose from over 2 000 existing profiles available from Gates's extensive mold inventory.

ATTRIBUTES

- › Available for all standard pitches
- › Non-marking, durable design
- › Over 2 000 existing shapes and constructions
- › Widths up to 18" / 450 mm available
- › Thermal bonding process fuses belt and profile together

APPLICATIONS

- › Pushing applications
- › General conveying applications
- › Glass conveying
- › Food conveying
- › Hygienic industry
- › Textile industry
- › Wood processing industry
- › Synchronous conveying applications

FABRICATION CAPABILITIES

- | | |
|------------------|--------------|
| › Minimum length | 500 mm |
| › Maximum length | 25 000 mm |
| › Maximum width | 450 mm / 18" |

Special dimensions and tolerances are available on request.

PROFILED BELTS-DESIGN RECOMMENDATIONS

TIMING BELTS

SELF TRACKING

FLAT BELTS

WIDE BELTS

ENDLESS BELTS

FINISHING

INFORMATION

Over 2.000 profile designs are already available from Gates extensive mold inventory. Our application engineers will help you to design new, custom built profiles which will fit your application.

Ultimate performance can be achieved by following the design guidelines outlined below:

1. PROFILE SPACING

It is recommended that the profile spacing "A" correspond with the pitch of the belt. This allows the best spacing tolerances, and minimizes the effects of the belt's overall length tolerance on the profile spacing. Profiles can be spaced on non-Pitch increments. However, if non-Pitch spacing is used, the cumulative tolerance of the belt length must be considered.

Please add the Profile Spacing Tolerance of ± 0.2 mm to calculate the profile spacing „A“ as follows:

Example

Profile Spacing Tolerance for pitch type T10: ± 0.54 mm

Profile Spacing "A" (notional value): 1 000 mm

Resultant positional tolerance: 1 000 mm ± 0.74 mm for pitch type T10

Tighter tolerances for profile spacing are available. Please contact Gates applications engineering for detailed information.

Pitch Tolerance for all Belt Types	
T / HTD® / STD / Imperial Pitches	± 0.54 mm per m
AT Pitches	+ 0.27 mm / -0.54 mm per m

2. PROFILE DIMENSIONS

The most important considerations while dimensioning a profile are the size of the base of the profile ("foot" of the profile) and the position of the profile on the belt. The profile thickness can affect the flexibility of the belt, and can determine the minimum allowable pulley diameter. The flexibility of the belt can be maximized, however, by positioning the profile directly over the tooth of the belt. As the thickness of the foot of the profile increases, the minimum pulley diameter in the system must be increased according to the table below:

Tolerances	
Profile Width Profile Length	± 0.25 mm / ± 0.01 " ± 0.25 mm / ± 0.01 "
The height tolerance of a profile in consequence of the fusion of the profile and belt at the welding area	+ 0.25 mm / -0.5 mm + 0.01" / -0.02"

Minimum Number of Teeth of Pulley for Profiles located over Tooth

Profile Foot Thickness (Inch)	1/16	1/8	3/16	1/4	5/16	3/8	7/16	1/2	5/8	3/4
Profile Foot Thickness (mm)	2	3	5	6	8	10	11	13	16	19
XL	10	10	18	25	40	50	60	100	---	---
L	12	12	12	18	30	40	50	60	100	---
H / H-HF	14	14	14	14	18	25	35	45	80	100
XH	18	18	18	18	18	18	18	20	35	50
T5	12	12	18	25	40	50	60	100	---	---
AT5 / ATL5	15	15	18	25	40	50	60	100	---	---
T10 / T10-HF	14	14	16	16	18	25	35	45	80	100
AT10	15	15	18	18	22	25	35	45	80	100
ATL10 / ATL10-HF	25	25	25	25	25	25	35	45	80	100
T20 / AT20	18	18	18	18	18	18	18	20	35	50
ATL20	30	30	30	30	30	30	30	30	35	50
HTD [®] 5 / STD5	14	14	16	25	40	50	60	100	---	---
HTD [®] 8 / STD8	20	20	20	24	30	40	50	60	100	---
HTD [®] 14	28	28	28	28	28	28	30	30	50	72
HTD [®] L14	43	43	43	43	43	43	43	43	50	72

Minimum Number of Teeth of Pulley for Profiles not located over Tooth

Profile Foot Thickness (Inch)	1/16	1/8	3/16	1/4	5/16	3/8	7/16	1/2	5/8	3/4
Profile Foot Thickness (mm)	2	3	5	6	8	10	11	13	16	19
XL	12	30	45	50	60	100	---	---	---	---
L	12	20	40	45	55	60	70	80	100	---
H / H-HF	14	14	25	30	45	50	55	65	80	100
XH	18	18	20	30	40	45	50	54	58	60
T5	12	30	45	50	60	100	---	---	---	---
AT5 / ATL5	15	30	45	50	60	100	---	---	---	---
T10 / T10-HF / AT10	18	20	30	40	45	50	55	65	80	100
ATL10 / ATL10-HF	25	25	30	40	45	50	55	65	80	100
T20 / AT20	18	18	20	30	40	45	50	54	58	60
ATL20	30	30	30	30	40	45	50	54	58	60
HTD [®] 5 / STD5	18	30	45	50	60	100	---	---	---	---
HTD [®] 8 / STD8	20	20	40	45	55	60	70	80	100	---
HTD [®] 14	28	28	30	42	58	64	72	78	82	86
HTD [®] L14	43	43	43	43	58	64	72	78	82	86

* not available

PROFIED BELTS-DESIGN RECOMMENDATIONS

TIMING BELTS

SELF TRACKING

FLAT BELTS

WIDE BELTS

ENDLESS BELTS

FINISHING

INFORMATION

3. PROFILE STRENGTH

The strength, and therefore the capacity of the profile depends primarily on the size of the welded profile foot.

The strength of the profile is affected by the type and direction of the force applied to it. Under high loads, the failure mode will normally be either bending or distortion of the profile and belt, or in some cases, the polyurethane may actually tear. The strength of the profile is approximately 6 N/mm^2 according to the drawing opposite.

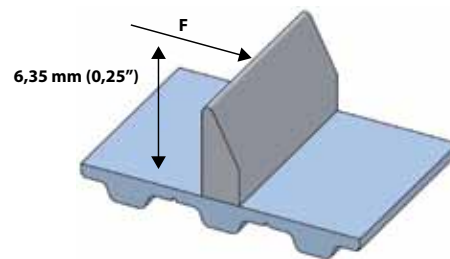

4. WIDE BASE PROFILES OR PROFILES WITH RELIEF

For profiles requiring a wide base, such as pushers, one foot should be left unwelded. This allows for flexing around the pulley yet it remains rigid when loaded.

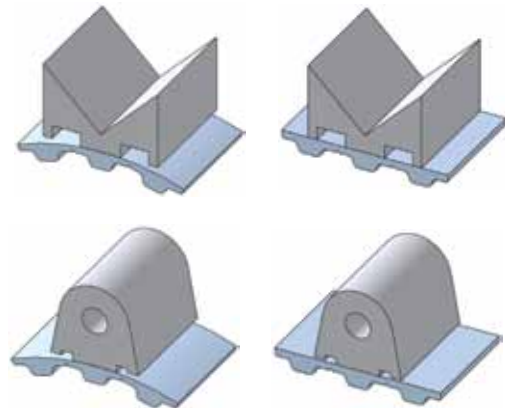

5. SEGMENTED PROFILES

If large profiles are required as carriers, then it is necessary, that they are either segmented or slotted.

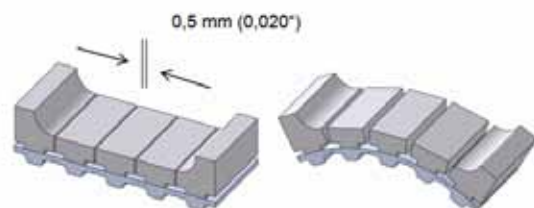

6. PROFILES WITH HOLES

Profiles with holes for securing paddles or other attachments can be produced. Holes are either drilled before bonding, or are molded into the profile depending upon the volume and requirements of the application. Tolerances of the hole placement depends upon whether the holes are drilled or molded.

The tolerance of the hole from the belt surface is subject to the bonding process of the profile foot and the belt surface. Generally, tolerances are as shown on the right-hand side

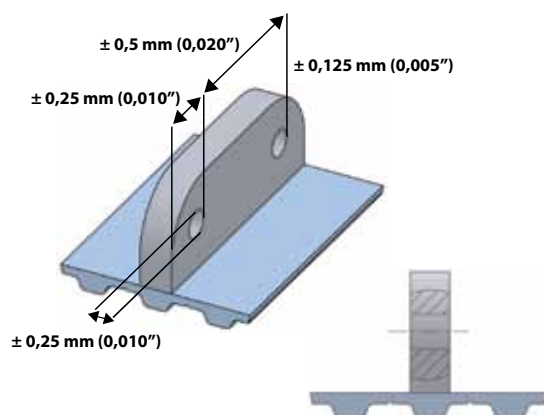

7. PROFILES WITH INSERTS

Profiles can be molded with metallic inserts. These are particularly useful in some applications to replace roller chains with attachments.

The actual inserts can either be manufactured by Gates or provided by the customer.

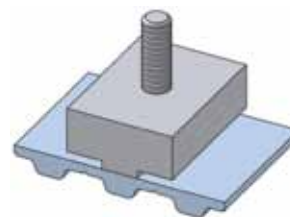

8. FLASH BEAD

The welding process can cause a weld bead of polyurethane between belt back and the lower profile edge. This can be removed on customer request.

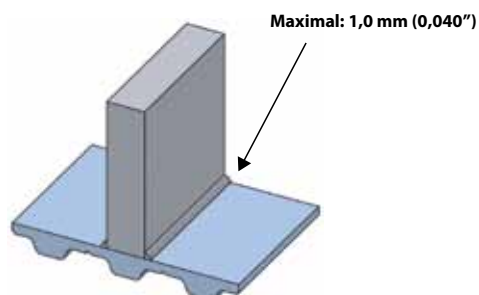

PROFIED BELTS-DESIGN RECOMMENDATIONS

TIMING BELTS

SELF TRACKING

FLAT BELTS

WIDE BELTS

ENDLESS BELTS

FINISHING

INFORMATION

9. PERPENDICULARITY

All profiles are perpendicular to $\pm 1^\circ$.

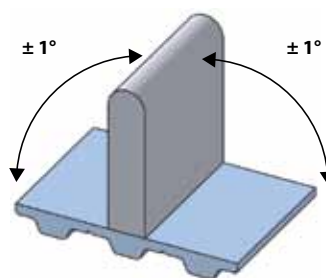

10. ORDERING

When ordering a profiled belt, it is advisable to submit a drawing of the profiled belt. For your convenience standard drawing forms are available from our Applications Engineering Department. Once a design is finalized, Gates will submit the drawing to the customer for approval. This custom belt drawing numbers should be used for future ordering.

PROFILE SELECTOR

Our online Profile Selector Tool allows you to:

- › Find the right profile for your application
- › Download of drawings for each selection
- › Review minimum pulley recommendations
- › Go to our website: www.gatesmectrol.com
- › On the right hand side you will find the item *Tool Set*
- › Click on *Profiles Selector 2* to start the application

Please contact our Applications Engineering group for special profile shapes, dimensions or tolerances.



Profile Search By Shape and Features

Geometric Shape:

All

Pentagon

Round Top

Cylinder

Standard Rectangle

Half-round

Other Rectangular

T shape

Trapezoid

U Shape

Triangle

V shape

Others

Features:

All

Holes, Vertical

Holes, along belt

Holes, across belt width

Support Leg – Back only

Support leg – Front and Back

Metal Threaded Insert – Male

Metal Threaded Insert – Female

Profile Dimensions : Metric (mm) Imperial (inches)

Length : Min. Max.

Height : Min. Max.

Thickness : Min. Max.

Weld Foot : Min. Max. Reset

[View Matching Profiles](#)

1418

Results

[Profile Home](#)

[Gates Mectrol](#)

developed by [NauTech IT Solutions, LLC](#)

GATES POLYURETHANE BELT PROGRAM ◊ GATES.COM/EUROPE/PU

145

FINISHING

SPECIAL PROCESSING

TIMING BELTS

SELF TRACKING

FLAT BELTS

WIDE BELTS

ENDLESS BELTS

FINISHING

INFORMATION

Gates offers further finishings for belts to achieve a variety of application requirements. From grinded edges or surfaces to tight tolerances, punching or machining holes and slots to CNC machining of three dimensional contours - Gates provides for all needs customized solutions.

Milling

Minimum Length	500 mm
Maximum Length	30.000 mm
Minimum Width	10 mm
Maximum Width	450 mm

Punching

Minimum Length	500 mm
Maximum Length	30.000 mm
Minimum Width	10 mm
Maximum Width	450 mm
Minimum Hole Diameter	1,0 mm
Maximum Hole Diameter	10 mm

Grinding

Minimum Length	480 mm
Maximum Length	No Limitation
Minimum Width	10 mm
Maximum Width	450 mm

Removing individual teeth

For precise positioning of deats

Slotting

The flexibility can be increased by cross grooving thick coatings

Our Applications Engineering Department will help you with your custom requirements.

ADVANTAGES

- > Unlimited adaptability for nearly all dimensions, contours and configurations
- > Combination of flexible base belt manufacturing and additional fabrication in one hand.

EXAMPLE OF USE

- > Vacuum conveying belts for pulling applications

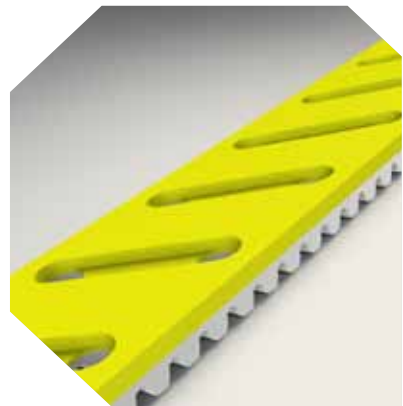
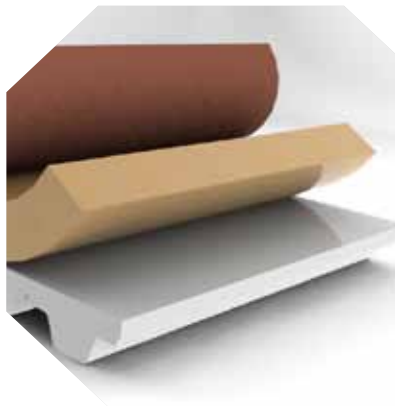
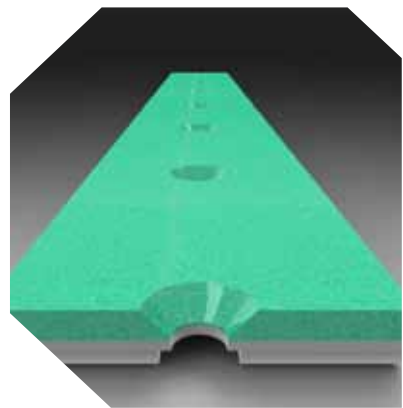
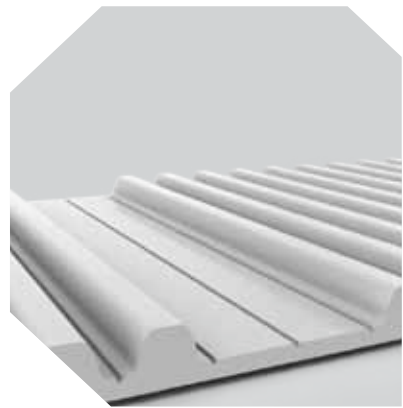
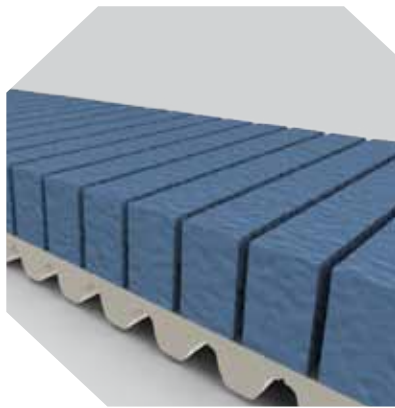

TIMING BELTS

SELF TRACKING

FLAT BELTS

WIDE BELTS

ENDLESS BELTS

FINISHING

INFORMATION

1. ABBREVIATIONS

Please consider the following abbreviations and symbols for calculation basis:

a	Acceleration [m/s ²]	g	Gravitational Acceleration [m/s ²]
A_V	Vacuum Area [m ²]	L	Timing Belt Length [mm]
β	Angle of Inclination [°]	l	Gauge Length during Frequency measurement [mm]
c_R	Overall Stiffness [N]	$L1$	Tight Side Length [mm]
c_{sp}	Belt Stiffness [N]	$L2$	Slack Side Length [mm]
d	Diameter	M	Torque
Δx	Elongation [mm]	m	Mass [kg]
Δx_{Pos}	Positional Deviation [mm]	m_a	Mass of accumulated Good [kg]
f	Frequency [Hz]	m_e	Mass of Counter Weight [kg]
F_1	Tight Side Belt Force [N]	m_F	Mass of Transported Goods [kg]
F_{1all}	Allowable Belt Force [N]	μ	Coefficient of Friction between Belt and Support
F_{1max}	Maximum occurring Belt Force [N]	μ_a	Coefficient of Friction between Belt and transported Material
F_{2opt}	Optimal Slack Side Force [N]	n	Revolutions per minute [1/min]
F_a	Acceleration Force [N]	p	Vacuum [N/m ²]
F_{Break}	Ultimate Tensile Strength [N]	P_{Motor}	Motor Power on Output Shaft [kW]
F_e	Effective Force [N]	r_{pulley}	Radius of Driver Pulley [mm]
F_{eall}	Allowable Effective Force [N]	Si_{Break}	Safety Factor on Breaking Force
$F_{eallapp}$	Maximum Allowable Effective Force Application [N]	Si_{F1}	Safety Factor on allowable Belt Force
F_f	Friction Force [N]	Si_{Fe}	Safety Factor on Allowable Effective Force
F_{Fa}	Friction Force during accumulation [N]	t_m	Tooth in mesh Factor
F_{FV}	Friction Force due to Vacuum [N]	T_{Motor}	Torque of Output Shaft [Nm]
F_g	Gravitational Force [N]	t_v	Speed Factor
F_{pre}	Force for Pre-tensioning [N]	v	Speed [m/sec]
F_{Stress}	Load Factor	z_m	Teeth in mesh
F_w	Externally applied working load [N]		

2. FORCES / FORCES FOR TIMING BELT DRIVES

a. Conveying Applications

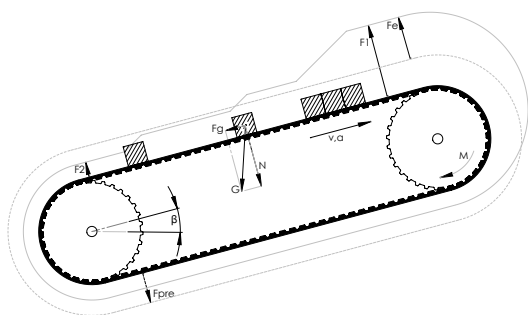

b. Linear Positioning

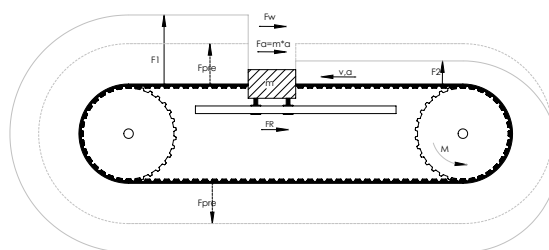

c. Closed Power Transmission Drives

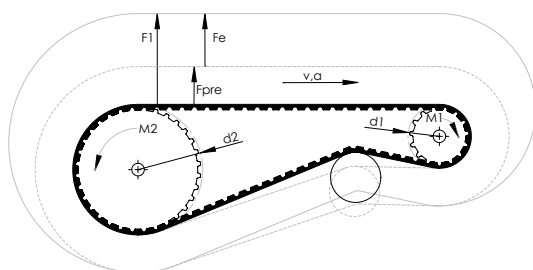

d. Lifting Applications

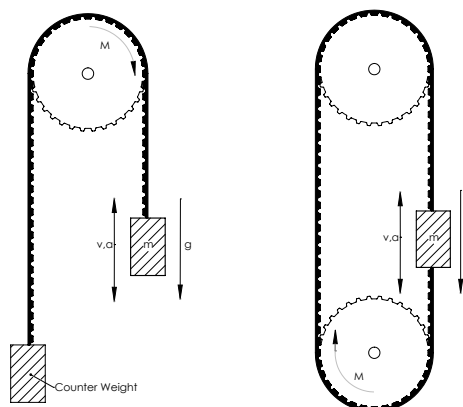

3. BASICS

a. Load Factor F_{Stress}

If no real-life testing results are available for the design of timing belt applications we recommend a load factor for calculating the effective force F_e , associated forces for pre-tensioning F_{pre} and tight side belt force F_1 .

Negative effects on the timing belt service life such as shocks are avoided through the Load Factor. The following list is provided as a guide for establishing a suitable factor:

Load	Load Factor	Examples
Uniform	1,2 ... 1,5	Conveyor for light goods, vial filling systems, medical devices, gauges, light wood processing machines, light bearing technology, linear motion slides
Weak impact load	1,5 ... 1,8	Wood processing machines, bearing technology, rack feeders, lathes, washing machines, mixing machines, vibration testing machines
Average impact load	1,8 ... 2,2	Hoisting devices, textile machines, extruders, paper handling
Heavy impact load	2,2 ... 2,5	Brickworks, molding press, coining machines, hammer mills

b. Tooth in mesh Factor t_m / Speed Factor t_v

The factors listed below are required to correct the Allowable Effective Force:

table 1

Tooth in mesh Factor t_m	
No. of Teeth in mesh	Tooth in mesh Factor
z_m	t_m
3	0.39
4	0.5
5	0.59
6	0.67
7	0.74
8	0.8
9	0.85
10	0.89
11	0.92
12	0.95
13	0.97
14	0.99
15	1

table 2

Speed Factor t_v	
Speed	Factor
m/s	t_v
0	1
1	0.99
2	0.98
3	0.97
4	0.95
5	0.93
6	0.9
7	0.87
8	0.84
9	0.81
10	0.77

c. Braking / Emergency Shutdown

For the following calculations the review of the peripheral forces occur due to normal braking maneuvers and especially emergency operations are of highest interest.

If the forces during these operation are bigger than the tangential forces based on lateral movement, further calculation of the force for pre-tensioning and the allowable belt force are needed on the basis of higher loads.

4. CALCULATION OF CONVEYING APPLICATIONS

a. Calculation of Effective Force F_e

The effective force F_e at the driver pulley is derived from the sum of all individual forces resisting the belt motion. The individual loads contributing to the effective force must be identified and calculated based on the loading conditions and drive configurations. To determine the Effective Force please use the method for conveying as follows:

$$F_e = \sum F_{\text{Resistance}} \times F_{\text{Stress}}$$

i. Friction Force F_F

The friction force between the timing belt and the slider bed due to weight of the conveyed good vertically to the direction of conveyance.

$$F_F = \mu \times g \times m_F \times \cos\beta$$

ii. Friction Force during accumulation F_{Fa}

The friction force between the timing belt, slider bed and the conveyed Material due to the mass component of the accumulated Material vertically to the direction of conveyance.

$$F_{Fa} = (\mu + \mu_a) \times g \times m_a \times \cos\beta$$

iii. Friction Force due to Vacuum F_{FV}

The friction force between the timing belt and the slider bed due to the vacuum for fixation of conveyed goods

$$F_{FV} = \mu \times p \times A_V$$

iv. Gravitational Force F_G

Force due to the mass component of the conveyed good parallel to the direction of conveyance.

$$F_G = m_F \times g \times \sin\beta$$

v. Acceleration Force F_a

Force to accelerate the mass of the conveyed good.

$$F_a = m_F \times a$$

vi. Further Forces

Motion resistance on the basis of belt mass, idler or similar are normally insignificant, but may have a decisive influence on the total value of the effective force and therewith on the belt load as well. The importance of mentioned influences has to be estimated throughout the calculations – in extreme cases the component forces must be calculated and considered.

b. Calculation of Force for Pre-tensioning F_{pre}

i. Real calculated Pre-tension

For trouble-free operation, it is necessary that the slack side does not fall below a certain tension. The pre-tension prevents jumping of the pulley teeth during belt operation. In order to collect the pre-tension, the optimal slack side force has to be ascertained as follows:

$$F_{2opt} = (0,1...0,3) \times F_U$$

Higher values are recommended for longer belt lengths.

Assuming an optimal slack side force the force for pre-tensioning is calculated considering the tight side length L_1 and the total timing belt length L as follows:

$$F_{pre} = F_{2opt} + F_e \times \frac{L_1}{L}$$

ii. Minimum Factor for Pre-tensioning

In most cases the selection of the belt type and its width is not carried out by existing applied loads, but on the geometry of the transported material. In most cases the result of this choice is an oversized belt drive the required pre-tension can hardly be determined based on calculation bases. For proper operation the Factor for pre-tensioning should be set as follows:

$$F_{pre} = 0,3 \times F_{1all}$$

c. Calculation of Tight Side Belt Force F_1

In the worst case the tight side belt force results as follows (conveyor moving at full load):

$$F_1 = F_e + F_{pre}$$

d. Belt Selection

To select the matching application for the belt type and width by using the values determined above (F_e and F_1) have to be compared with the valid data from our catalogue. After the first selection, the resulting pulley teeth have to be detected. The determined number of teeth and the angle of contact are the basis for the number of teeth which are constantly engaged to the pulley and which can be used for power transmissions.

The allowable effective force F_{eall} for the number of teeth smaller than 15 has to be rectified with the help of a tooth in mesh factor t_m which can be taken from *table 1*. The same method is allowed for conveying velocity. The needed speed factor t_v for speed can be taken from *table 2*. The outcome is a maximum allowable effective Force Application as follows:

$$F_{eallapp} = F_{eall} \times t_m \times t_v$$

$F_{eallapp}$ and F_{1all} should be larger than the actual prevailing forces in the application.

$$F_{eallapp} > F_e$$

$$F_{1all} > F_1$$

c. Calculation of Safety Factor SF

- i. Safety factor on allowable effective force SF_{F_e}

$$SF_{F_e} = F_{eallapp} / F_e$$
- ii. Safety factor on allowable belt force SF_1

$$SF_1 = F_{1all} / F_1$$
- iii. Safety factor on ultimate tensile strength SF_{Break}

$$SF_{Break} = F_{Break} / F_1$$

5. CALCULATION OF LINEAR APPLICATIONS

a. Calculation of Effective Force F_e

The effective force F_e at the driver pulley is derived from the sum of all individual forces resisting the belt motion. The individual loads contributing to the effective force must be identified and calculated based on the loading conditions and drive configurations. To determine the effective force please use the method for conveying as follows:

$$F_e = \sum F_{Resistance} \times F_{Stress}$$

- i. Friction Force F_F
 The friction force between the conveyed material and the storing vertically to the direction of conveyance.

$$F_F = \mu \times g \times m \times \cos\beta$$
- ii. Gravitational Load F_G
 Force due to mass component parallel to the direction of conveyance.

$$F_G = m \times g \times \sin\beta$$
- iii. Acceleration Force F_a
 Force to accelerate the mass of the moved goods.

$$F_a = m \times a$$

iv. Further Forces

Motion resistance due to belt mass, idler or similar are normally insignificant, but may have a decisive influence on the total value of the effective force F_e and therewith on the belt load as well. The importance of mentioned influences has to be estimated throughout the calculations – in extreme cases the component forces must be calculated and considered.

b. Calculation of Force for Pre-tensioning F_{pre}

For trouble-free operation, it is necessary that the slack side does not fall below a certain tension. The pre-tension prevents jumping of the pulley teeth during belt operation. In order to collect the pre-tension, the optimal slack side force has to be ascertained as follows:

$$F_{2opt} = (0,1 \dots 0,3) \times F_e$$

Higher values are recommended for longer belt lengths.

Assuming an optimal slack side force, the force for pre-tensioning is calculated considering the tight side length L_1 and the total timing belt length L as follows:

$$F_{pre} = F_{2opt} + F_e \times \frac{L_1}{L}$$

c. Calculation of Tight Side Belt Force F_1

In the worst case the tight side belt force results as follows (application moving at full load):

$$F_1 = F_e + F_{pre}$$

d. Belt Selection

To select the matching application for the belt type and width by using the values determined above (F_e and F_1) have to be compared with the valid data from our catalog. After the first selection, the resulting pulley teeth have to be detected. The determined number of teeth and the angle of contact are the basis for the number of teeth which are constantly engaged to the pulley and which can be used for power transmissions. The allowable effective force F_{eall} for the number of teeth smaller than 15 has to be rectified with the help of a tooth in mesh factor t_m which can be taken from **table 1**. The same method is allowed for conveying velocity. The needed speed factor t_v for speed can be taken from **table 2**. The outcome is a maximum allowable effective force application as follows:

$$F_{eallapp} = F_{eall} \times t_m \times t_v$$

$F_{eallapp}$ and F_1 should be larger than the actual prevailing forces in the application.

$$F_{EallAn} > F_U$$

$$F_{1all} > F_1$$

e. Calculation of Safety Factor SF

- i. Safety factor on allowable effective force SF_{FE}

$$SF_{FE} = F_{eallapp} / F_e$$
- ii. Safety factor on allowable belt force SF_1

$$SF_1 = F_{1all} / F_1$$
- iii. Safety factor on ultimate tensile strength SF_{Break}

$$SF_{Break} = F_{Break} / F_1$$

f. Clamp Plates

The clamp plates should be accomplished that at least 8 teeth per belt end can be clamped. During the assembling process please consider to equally clamp the belt – the belt height has to be reduced by at least 0,2 - 0,3 mm.

6. CALCULATION OF CLOSED POWER TRANSMISSION DRIVES

Closed power transmission drives should be always realized as truly endless cast or flex belts. The use of endless welded timing belts is not recommended.

a. Calculation of Effective Force F_e

The Effective Force F_e can be calculated with the existing movement resistance as follows:

$$F_e = \sum F_{Resistance} \times F_{Stress} \quad \text{Quod vide} \rightarrow \text{conveying applications}$$

Furthermore the effective force can also be calculated with the existing driving power as follows:

$$F_e = (T_{Motor} \times 1000) / r_{pulley}$$

or

$$F_e = (19100 \times P_{Motor} \times 500) / (n \times r_{pulley})$$

b. Calculation of Force for Pre-tensioning F_{pre}

For trouble-free operation, it is necessary that the slack side does not fall below a certain tension. The pre-tension prevents jumping of the pulley teeth during belt operation. In order to collect the pre-tension, the optimal slack side force has to be ascertained as follows:

$$F_{2opt} = (0,1 \dots 0,3) \times F_e$$

Higher values are recommended for longer belt lengths.

Assuming an optimal slack side force, the force for pre-tensioning is calculated considering the tight side length L_1 and the total timing belt length L as follows:

$$F_{pre} = F_{2opt} + F_e \times \frac{L_1}{L}$$

c. Calculation of Tight Side Belt Force F_1

In the worst case the tight side belt force F_1 results as follows (application moving at full load):

$$F_1 = F_e + F_{pre}$$

d. Belt Selection

To select the matching application for the belt type and width by using the values determined above (F_e and F_1) have to be compared with the valid data from our catalog. After the first selection, the resulting pulley teeth have to be detected. The determined number of teeth and the angle of contact are the basis for the number of teeth which are constantly engaged to the pulley and which can be used for power transmissions. The allowable effective force F_{eall} for the number of teeth smaller than 15 has to be rectified with the help of a tooth in mesh factor t_m which can be taken from *table 1*. The same method is allowed for conveying velocity. The needed speed factor t_v for speed can be taken from *table 2*. The outcome is a maximum allowable effective force application as follows:

$$F_{eallapp} = F_{eall} \times t_m \times t_v$$

$F_{eallapp}$ and F_{1all} should be larger than the actual prevailing forces in the application.

$$F_{eallapp} > F_e$$

$$F_{1all} > F_1$$

e. Calculation of Safety Factor SF_i

- i. Safety factor on allowable effective force SF_{Fe}

$$SF_{Fe} = F_{eallapp} / F_e$$
- ii. Safety factor on allowable belt force SF_1

$$SF_1 = F_{1all} / F_1$$
- iii. Safety factor on ultimate tensile strength SF_{Break}

$$SF_{Break} = F_{Break} / F_1$$

7. CALCULATION OF LIFTING APPLICATIONS WITHOUT COUNTER WEIGHT, TWO SHAFTS

a. Calculation of Effective Force F_e

The effective force at the driver pulley is derived from the sum of all individual forces resisting the belt motion. The individual loads contributing to the effective force must be identified and calculated based on the loading conditions and drive configurations. To determine the effective force F_e please use the method for conveying as follows:

$$F_e = \sum F_{\text{Resistance}} \times F_{\text{Stress}}$$

i. Friction Force F_F

The friction force between the moved mass and its bearings.

$$F_F = \mu \times g \times m \times \cos\beta$$

ii. Gravitational Load F_G

Force due to mass component parallel to the direction of conveyance.

$$F_G = m \times g \times \sin\beta$$

iii. Acceleration force F_a

Force to accelerate the mass.

$$F_a = m \times a$$

iv. Further Forces

Motion resistance due to belt mass, idler or similar are normally insignificant, but may have a decisive influence on the total value of the effective force F_e and therewith on the belt load as well. The importance of mentioned influences has to be estimated throughout the calculations – in extreme cases the component forces must be calculated and considered.

b. Calculation of Factor for Pre-tensioning F_{pre}

For trouble-free operation, it is necessary that the slack side does not fall below a certain tension. The pre-tension prevents jumping of the pulley teeth during belt operation. In order to collect the pre-tension, the optimal slack side force has to be ascertained as follows:

$$F_{2\text{opt}} = (0,1 \dots 0,3) \times F_U$$

Higher values are recommended for longer belt lengths.

Assuming an optimal slack side force, the force for pre-tensioning is calculated considering the tight side length L_1 and the total timing belt length L as follows:

$$F_V = F_{2\text{opt}} + F_U \times \frac{L_1}{L}$$

c. Calculation of Tight Side Belt Force F_1

In the worst case the Tight Side Belt Force results as follows (Conveyor moving at full load):

$$F_1 = F_e + F_{pre}$$

d. Belt Selection

To select the matching application for the belt type and width by using the values determined above (F_e and F_1) have to be compared with the valid data from our catalogue. After the first selection, the resulting pulley teeth have to be detected. The determined number of teeth and the angle of contact are the basis for the number of teeth which are constantly engaged to the pulley and which can be used for power transmissions. The allowable effective force F_{eall} for the number of teeth smaller than 15 has to be rectified with the help of a tooth in mesh factor t_m which can be taken from **table 1**. The same method is allowed for conveying velocity. The needed speed factor t_v for speed can be taken from **table 2**. The outcome is a maximum allowable effective force application as follows:

$$F_{eallapp} = F_{eall} \times t_m \times t_v$$

$F_{eallapp}$ and F_{1all} should be larger than the actual prevailing forces in the application.

$$F_{eallapp} > F_e$$

$$F_{1all} > F_1$$

e. Calculation of Safety Factor SF

- i. Safety factor on allowable effective force SF_{Fe}

$$SF_{Fe} = F_{eallapp} / F_e$$

- ii. Safety factor on allowable belt force SF_1

$$SF_1 = F_{1all} / F_1$$

- iii. Safety factor on ultimate tensile strength SF_{Break}

$$SF_{Break} = F_{Break} / F_1$$

8. CALCULATION OF LIFTING APPLICATIONS, WITH COUNTER WEIGHT, 1 SHAFT

a. Calculation of Effective Force F_e

The effective force F_e at the driver pulley is derived from the sum of all individual forces resisting the belt motion. The individual loads contributing to the effective force must be identified and calculated based on the loading conditions and drive configurations. To determine the effective force please use the method for conveying as follows:

i. $F_e = m \times (g+a) - m_e \times (g-a)$

ii. Further Forces

Motion resistance due to belt mass, idler or similar are normally insignificant, but may have a decisive influence on the total value of the effective force F_e and therewith on the belt load as well. The importance of mentioned influences has to be estimated throughout the calculations – in extreme cases the component forces must be calculated and considered.

b. Calculation of Factor for Pre-tensioning F_{pre}

Not available for lifting applications with counter weight and one pulley.

c. Calculation of Tight Side Belt Force F_1

In the worst case the tight side belt force results as follows (conveyor moving at full load):

$$F_{1max} = m_{max} \times (a + g)$$

d. Belt Selection

To select the matching application for the belt type and width by using the values determined above (F_e and F_1) have to be compared with the valid data from our catalog. After the first selection, the resulting pulley teeth have to be detected. The determined number of teeth and the angle of contact are the basis for the number of teeth which are constantly engaged to the pulley and which can be used for power transmissions. The allowable effective force F_{eall} for the number of teeth smaller than 15 has to be rectified with the help of a tooth in mesh factor t_m which can be taken from *table 1*. The same method is allowed for conveying velocity. The needed speed factor t_v for speed can be taken from *table 2*. The outcome is a maximum allowable effective force application as follows:

$$F_{eallapp} = F_{Eall} \times t_m \times t_v$$

$F_{eallapp}$ and F_{1all} should be larger than the actual prevailing forces in the application.

$$F_{eallapp} > F_e$$

$$F_{1all} > F_{1max}$$

e. Calculation of Safety Factor SF

- i. Safety factor on allowable effective force SF_{Fe}

$$SF_{Fe} = F_{eallapp} / F_e$$
- ii. Safety factor on allowable belt force SF_1

$$SF_1 = F_{1all} / F_1$$
- iii. Safety factor on ultimate tensile strength SF_{Break}

$$SF_{Break} = F_{Break} / F_1$$

9. ELONGATION / POSITIONING ERROR IN TIMING BELT DRIVES**a. Elongation Δx**

The static elongation based on an applied force such as the pre-tension results as follows:

$$\Delta x = \frac{F \times L}{c_{Sp}}$$

b. Positioning Error Δx_{Pos}

The positioning error mainly depends on the total stiffness c_R of the slack and tight side.

$$c_R = c_{Sp} \times \frac{L}{L_1 \times L_2}$$

Note that c_R is at its minimum when the tight and slack sides are equal.

Determine the positioning error Δx_{Pos} due to belt elongation caused by e.g. the effective force F_e :

$$\Delta x_{Pos} = \frac{F}{c_R}$$

10. TIMING BELT CONSTRUCTION

a. Pre-tensioning F_{pre}

For proper adjustment of pre-tensioning F_{pre} Gates recommends the Sonic Tension Meter 507 C which directly specifies the pre-tension in Newton.

When using prior tension meters the conversion of the pre-tension is required. The conversion results as follows:

$$f = \sqrt{\frac{F_{pre}}{4 \times m \times l^2}}$$

b. Assembling Instructions

The timing belt should be placed around the pulleys without any tension. Using the tensioning device, apply the calculated pre-tension to the belt. After applying the pre-tension, lock all adjustable shafts into place. If the shafts are fixed, the timing belt has to be assembled together with the pulleys.

ABBREVIATIONS

TIMING BELTS

SELF TRACKING

FLAT BELTS

WIDE BELTS

ENDLESS BELTS

FINISHING

INFORMATION

The specifications listed are based on Gates experience. However, our specifications and data do NOT cover all possible belt drive conditions. It is the responsibility of the belt drive system designer to ensure Gates belts are appropriate for a given system and application. The provided data is representative of our in-house experience and does not necessarily match product performance in industrial use. Gates cannot assume any liability concerning the suitability and process ability of our products. We also cannot assume liability for process results, damages or consequential damages associated with the use of our products.

Do not use Gates belts in applications that depend solely upon the belt to raise/lower, support or sustain a mass without an independent safety backup system. Gates products are not suitable for applications in aircraft.

All information contained are subject to change without notice.

ABBREVIATIONS

Polyurethane		Belt Types	
R1	92 Shore A	R	Roll stock
R2	85 Shore A	G	Open ended
FDA	85 Shore A / FDA approval	P	Punched only belts
R3	90 Shore A / STAND cast belts	E	Endless welded belts
R4	94 Shore A / antistatic features	S	Gates Synchro Power® (Cast) Belts
EUF85	85 Shore A / suitable for food use	F	Truly Endless Flex Belts
EUF92	92 Shore A / suitable for food use		

Pitches and Cord Types		Polyamide and Special Fabrics	
SL	Steel cord	NB	Polyamide fabric on back
L	Reinforced cord	NT	Polyamide fabric on tooth side
HF	High flexible steel cord	NTB	Polyamide fabric on tooth and back
NIRO	Stainless steel cord	ECO	Antistatic ECO fabric on tooth and back
KV	Aramide cord	ATB	Antistatic fabric on tooth and back
DT	Double sided cast belts		

Approvals	
FDA	Approval by the U.S. Food and Drug Administration according to regulation no. 177.2600-Rubber Articles for repeated use
EU	EU approval for materials made of polyurethane, which are used for food applications according to the following EU regulations and guidelines: VO (EG) No. 1935 / 2004 § 4, EG Regulation 2002 / 72 / EG-completion 2007 / 19 / EG, Regulation 82 / 711 / EWG and Regulation 85 / 572 / EWG

Backings and Fabrications	
HB	High Back Backing / backing hardness depends on on belt hardness
Min. pulley diameter in mm	Pulley diameter factor x material thickness



NOTES

Gates Mectrol and Synchro-Power® are registered trademarks.
All other trademarks used herein are the property of their respective owners.

© Gates GmbH 2012. All rights reserved.

TIMING BELT

SELF TRACKING

FLAT BELTS

WIDE BELTS

ENDLESS BELTS

FINISHING

INFORMATION



POWERING PROGRESS™

Gates.com/europe/pu

GERMANY

GATES MECTROL GMBH

Werner-von-Siemens-Str. 2
64319 Pfungstadt

T [49] 06 157 9727 0 / **F** [49] 06 157 9727 272

GERMANY

GATES GMBH

Eisenbahnweg 50
52068 Aachen

T [49] 241 5108 226 / **F** [49] 241 5108 297

ITALY

GATES S.R.L.

Via Senigallia 18 - Blocco A
20161 Milano MI

T [39] 02 662 16 21 / **F** [39] 02 662 21 851

BELGIUM

GATES POWER TRANSMISSION EUROPE BVBA

Dr. Carlierlaan 30
9320 Erembodegem

T [32] 53 76 28 41 / **F** [32] 53 76 26 09

FRANCE

GATES FRANCE S.A.R.L.

B.P. 37
12, Rue de la Briqueterie
Zone Industrielle, 95380 Louvres

T [33] 1 34 47 41 45 / **F** [33] 1 34 72 20 54

RUSSIA

GATES CIS LLC

Kosmodamianskaja nab. 52, building 4
Business Centre Riverside Towers, 6th floor
115054 Moscow

T [7] 495 933 83 71 / **F** [7] 495 933 83 78

EAN code 5414465699177
BPCS PN 9997-E2/20166

Your distributor:

GPU_K1012_EN

Technical specifications can change without prior notice.

© Gates Mectrol GmbH 2012

Germany - 10/12.

