

Made for Motion



EVOLASTIC®

Highly flexible couplings

ktr.com

Fast, easy and reliable - with the product finder and our online tools

The product finder allows you to get to the suitable product in just a few steps. For this purpose either make use of the search function if you already know the product or use the full-text search which guides you to the requested result via various product-specific filters. Our selection tools speed up the detailed product selection. Few tech-

nical data suffice to rapidly find the right product for your application in the configurators - without having to browse catalogues lengthily.



Online tools

Tailor-made to your specifications - make use of our online tools



Product finder

The suitable product for your application - fast and simple with our product finder.

EVOLASTIC®

Highly flexible couplings

Examples of application



Pumps



Shredders



Tractors



Cooling towers



Stage technology



Snow groomers



Yachts



Piston compressors

EVOLASTIC®

Highly flexible couplings

Properties of flexible jaw and pin & bush couplings

					
Product	ROTEX®	EVOLASTIC®	POLY-NORM®	POLY	REVOLEX®
Type	Torsionally flexible jaw coupling	Highly flexible jaw coupling	Torsionally flexible jaw coupling	Torsionally flexible jaw coupling	Torsionally flexible pin & bush coupling
Features					
Torsionally flexible	●	●	●	●	●
Highly flexible		●			
Damping vibrations	●	●	●	●	●
Maintenance-free	●	●	●	●	●
Axial plug-in	●	●	●	●	●
Shear type				●	
Fail-safe	●	●	●		●
Compensating for misalignment	●	●	●	●	●
Types					
Variant diversity	very high	very high	average	average	high
Special features	extensive basic programme available from stock while customised solutions can be realized	reducing torsional vibrations and compensating for misalignment above average with compact dimensions, extremely flexible for individual drives	basic programme available from stock	basic programme available from stock	extensive programme, ideal for customised solutions, for applications with high performance ranges
Applications / core industries	manifold applications, applicable in all industries	flexible all-rounder coupling for wide applications in mechanical and plant engineering	pump industry, industrial gearboxes	chemical pumps, high-pressure pumps, ...	industrial gearboxes, conveyor systems, industrial fans, cableways, agitators, generators, ...
surface	allover machining, very good dynamic properties	machined, optionally available with corrosion protection, soft elastomer	shell surface machined	shell surface machined	allover machining, good dynamic properties
Torque range T_{KN} [Nm]					
Min.	7.5	100	40	42	4,300
Max.	35,000	5,600	67,000	6,100	1,350,000
Max. circumferential speed v [m/s]					
Cast EN-GJL (dynamic balancing)	35		35	35	35
Steel + cast EN-GJS (dynamic balancing)	60	60			60
Hub materials available					
Steel (semi-finished product) » customised solutions available	●	●			●
Cast iron (GJL) » subject to mould	●		●	●	●
Nodular iron (GJS) » subject to mould	●		○		○
Aluminium wrought products (Al-H) » customised solutions available	●				
Aluminium diecast (Al-D)	●				
Stainless steel	●	On request			
Corrosion-protected types	●	○	○	○	●
Spiders / elastomers					
Material	T-PUR®, PA, PEEK, Hytrek, ...	NR + EPDM	NBR (up to size 180) T-PUR® (from size 200)	NBR	NR, NBR NBR electrically insulating
Degree of hardness	flexible to torsionally rigid	highly flexible compounds W, S, M	flexible	flexible	flexible
Temperature range in °C, min. / max. (standard)	-50 / +120	-40 / +90	-30 / +80	-30 / +80	-30 / +80
Temperature range in °C, min. / max. (special)	-50 / +250	-30 / +110	-30 / +80	-30 / +80	-50 / +80

● ≈ Standard
○ ≈ On request

EVOLASTIC®

Highly flexible couplings

Properties of flexible jaw and pin & bush couplings

					
Product	ROTEX®	EVOLASTIC®	POLY-NORM®	POLY	REVOLLEX®
Type	Torsionally flexible jaw coupling	Highly flexible jaw coupling	Torsionally flexible jaw coupling	Torsionally flexible jaw coupling	Torsionally flexible pin & bush coupling
Geometries					
Design	compact	short	short	short	short
Mass moment of inertia	low	low	average	high	average
Shaft distance dimension	low / average	low	low	low	low
Types (extract)					
Elastomers can be radially disassembled » with no need of displacing driving/driven side	AFN, AH, SH, ZR, DF, DFN, CF-H	D2H, DFH	ADR, ADR-SB	PKD	Standard
Intermediate shaft types » bridging larger shaft distances	ZR, ZWN	D2H, DFH	-	-	customised
Standard spacers 100 mm to 250 mm	ZS-DKM-H	-	AZR	PKA	customised
Shaft-to-shaft connection	Standard	EH, E2H, EHP, E2HP	Standard	Standard	Standard
Flange-to-shaft connection	CF, CFN	EFH, EFHP	-	-	customised
Flange-to-flange connection » particularly short mounting length	DF, DNF	customised	-	-	customised
Double-cardanic » compensating for big displacements, lower restoring forces	ZS-DKM-H, ZR, ZWN	D2H, DFH	-	-	-
Certifications / type examinations					
ATEX 	●	○	●	●	●
UL-listed 	●	○			
GOST R / GOST TR 	●	○	●	●	●
DNV/GL 	●	○			●
ABS 	●	○			○
Bureau Veritas 	●	○			○
LR 	○	○			○
RS CLASS 	○	○			○
CCS 	○	○			○
ClassNK 	○	○			

● = Standard
○ = On request

EVOLASTIC®

Highly flexible couplings

Description of product and application

The EVOLASTIC® is a highly flexible, non-slip and backlash-free shaft and flange coupling for flexible use in a large number of main and auxiliary drives in mechanical and plant engineering.

Subject to the elastomer element pre-stressed to pressure, the coupling is able to reduce torsional vibrations in the drive train and absorb overload shocks smoothly. Structure-borne noise is damped efficiently. At the same time it offsets misalignment above average in three dimensions (axially, radially and angularly).

The key component of this series is a vulcanised, circularly closed elastomer element made of natural rubber (WN, SN, MN, up to 90 °C) or for higher temperatures made of synthetical EPDM material (WE, SE, ME, up to 110 °C). The various kinds of rubber hardness cover one application and torque range per size.

The basic variants distinguish between directly screwed types and pluggable types. They cover all practical mounting conditions ranging from a finished individual component through hub/hub and flange/hub applications to the driving shaft. Apart from that the product portfolio allows for highly individual and flexible mounting options, tailor-made for the special application.



Technical data													
Size	Elastomer type ²⁾	Torque [Nm] ¹⁾				Dynamic torsion spring stiffness C _{dyn.} [Nm/rad]		Relative damping ψ [-]		Perm. damping power P _{KW} [W]		Operating speed [rpm]	
		T _{KN}	T _{Kmax}	T _{Kmax1}	T _{KW}	30 °C	60 °C	30 °C	60 °C	30 °C	60 °C	n	η _{max.}
12	SN	100	200	300	40	900	720	0.80	0.64	25	15	4,500	5,000
	MN	120	240	360	48	1,500	1,200	1.10	0.88			5,400	6,000
24	SN	200	400	600	80	2,000	1,600	0.80	0.64	40	24	3,780	4,200
	MN	240	480	720	96	3,600	2,880	1.10	0.88			4,500	5,000
48	SN	420	840	1,260	168	6,800	5,440	0.80	0.64	75	45	3,780	4,200
	MN	480	960	1,440	192	13,500	10,800	1.10	0.88			4,500	5,000
60	SN	500	1,000	1,500	200	4,600	3,680	0.80	0.64	80	48	3,240	3,600
	MN	600	1,200	1,800	240	7,750	6,200	1.10	0.88			3,600	4,000
86	SN	760	1,520	2,280	304	12,500	10,000	0.90	0.72	90	54	3,600	4,000
	MN	860	1,720	2,580	344	21,000	16,800	1.10	0.88			4,050	4,500
125	SN	1,100	2,200	3,300	440	8,800	7,040	0.80	0.64	120	72	2,880	3,200
	MN	1,250	2,500	3,750	500	16,000	13,600	1.10	0.88			3,240	3,600
200	SN	1,700	3,400	5,100	680	29,000	23,200	0.90	0.72	150	90	3,060	3,400
	MN	2,000	4,000	6,000	800	44,000	35,200	1.10	0.88			3,240	3,600
280	WN	2,400	4,800	7,200	960	38,000	30,400	0.70	0.56	170	102	2,700	3,000
	MN	2,800	5,600	8,400	1,120	78,000	62,400	1.10	0.88			3,060	3,400
360	WN	3,200	6,400	9,600	1,280	48,500	38,800	0.70	0.56	200	120	2,700	3,000
	SN	3,400	6,800	10,200	1,360	67,000	53,600	0.90	0.72			3,060	3,400
560	WN	5,000	10,000	15,000	2,000	115,000	92,000	1.10	0.88			3,060	3,400
	SN	5,200	10,400	15,600	2,080	73,500	58,800	0.80	0.64			2,250	2,500
	MN	5,600	11,200	16,800	2,240	105,000	84,000	1.00	0.80	240	144	2,520	2,800
						138,000	110,400	1.10	0.88			2,700	3,000

¹⁾ T_{KN} Torque that can be constantly transmitted over the entire speed range.
T_{Kmax} Transient torque peaks (e. g. resonance passage), max. 100,000 load alternation pulsating / 50,000 load alternation vibratory
T_{Kmax1} Torque loads rarely, max. 1,000 load alternation
For selection consider DIN 740 part II (operating factor, temperature factor), parameters for an ambient temperature of 20 °C.
²⁾ Higher strength on request.

Types

Types screwed axially	
E	Elastomer + set of screws
EH	Elastomer + hub (drive)
E2H	Elastomer + two hubs (driving and driven side)
EFH	Elastomer + flange (drive) + hub (driven side)
D2H	Two elastomers + intermediate shaft + two hubs
DFH	Two elastomers + intermediate shaft + flange and hub



Types plugged in axially	
EP	Elastomer + locking pin
EHP	Elastomer + hub (drive), pluggable
E2HP	Elastomer + two hubs (driving and driven side), pluggable
EFHP	Elastomer + flange (drive) + hub (driven side) pluggable



EVOLASTIC®

Highly flexible couplings

Types of hubs

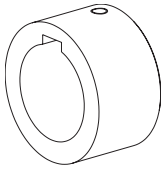

Type 1.0
Hub with feather keyway and setscrew

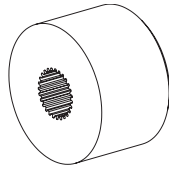

Type 3.0
Hub with spline bore

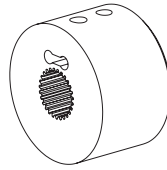

Type 3.1
Clamping hub N with spline bore

Other hub connections on request.

Examples:

- Slotted clamping hub
- Clamping ring hub
- taper or cylindrical press fit
- split hub

Displacements / Displacement stiffness

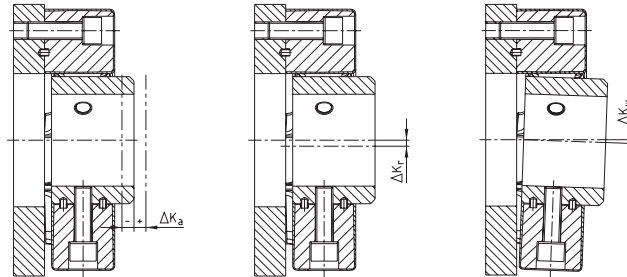

EVOLASTIC® size	12	24	48	60	86	125	200	280	360	560
Perm. axial displacement ΔK_a [mm]	±2.5	±3.0	±2.5	±3.0	±3.0	±3.5	±3.0	±3.5	±4.0	±4.0
Perm. radial displacement ΔK_r [mm]	1,500 rpm	2	2	2	2.5	2	2.5	2.5	3	3
	Max. ¹⁾	3.6	3.6	3.6	4.5	3.6	4.5	4.5	5.4	5.4
Perm. angular displacement ΔK_w [°]	1,500 rpm	3.0	3.0	2.0	3.0	2.0	3.0	2.0	2.0	2.0
	Max. ¹⁾	6.0	6.0	4.0	6.0	4.0	6.0	4.0	4.0	4.0

¹⁾ With assembly for a short time resp. rarely with downtime or start-up operation as well as exceptional load conditions.

The radial and angular displacement of a coupling element refers to an operating speed of 1,500 RPM. Following the graph the permissible operating displacement increases with lower speed or reduces with rising speed by the factor f_{rpm} . The combination of radial and angular displacement in an application is divided up as a percentage. The permissible displacement refers to the total of alignment and operating displacement.

Size	Elastomer hardness	Axial stiffness C_a [N/mm]		Radial stiffness C_r [N/mm]		Angular stiffness C_w [N/°]	
		30 °C	60 °C	30 °C	60 °C	30 °C	60 °C
12	S	50	40	280	224	2.0	1.6
	M	70	56	400	320	3.0	2.4
24	S	70	56	400	320	4.0	3.2
	M	100	80	550	440	5.0	4.0
48	S	270	216	1,000	800	10	8.0
	M	420	336	1,500	1,200	15	12
60	S	100	80	440	352	10	8.0
	M	120	96	650	520	14	11
86	S	390	312	1,300	1,040	24	19
	M	490	392	1,625	1,300	30	24
125	S	150	120	650	520	15	12
	M	200	160	920	736	22	18
200	S	420	336	1,700	1,360	45	36
	M	525	420	2,125	1,700	56	45
280	W	460	368	1,150	920	58	46
	M	800	640	2,800	2,240	95	76
360	W	450	360	1,800	1,440	66	53
	S	550	440	2,200	1,760	80	64
560	M	710	568	2,500	2,000	100	80
	W	380	304	1,950	1,560	95	76
	S	480	384	2,500	2,000	120	96
	M	620	496	3,000	2,400	150	120

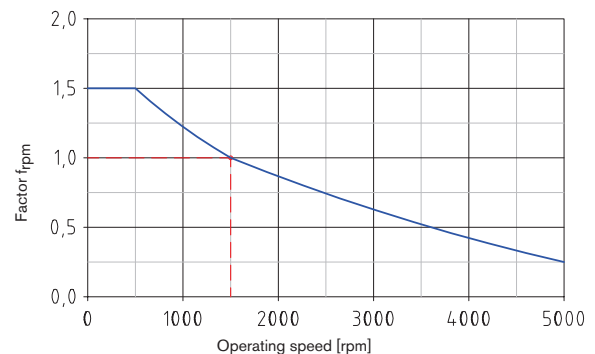
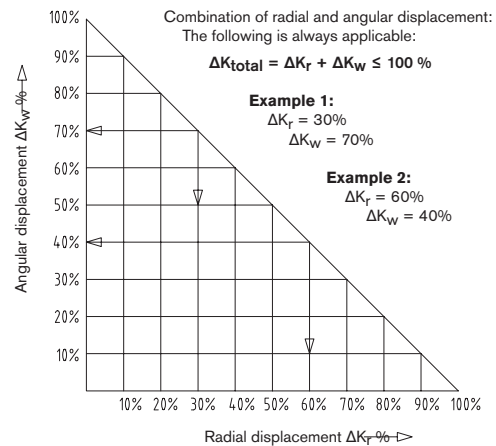

EVOLASTIC® E

Highly flexible couplings

Individual element - available in various kinds of Shore hardness



For legend of pictogram please refer to flapper on the cover



Components

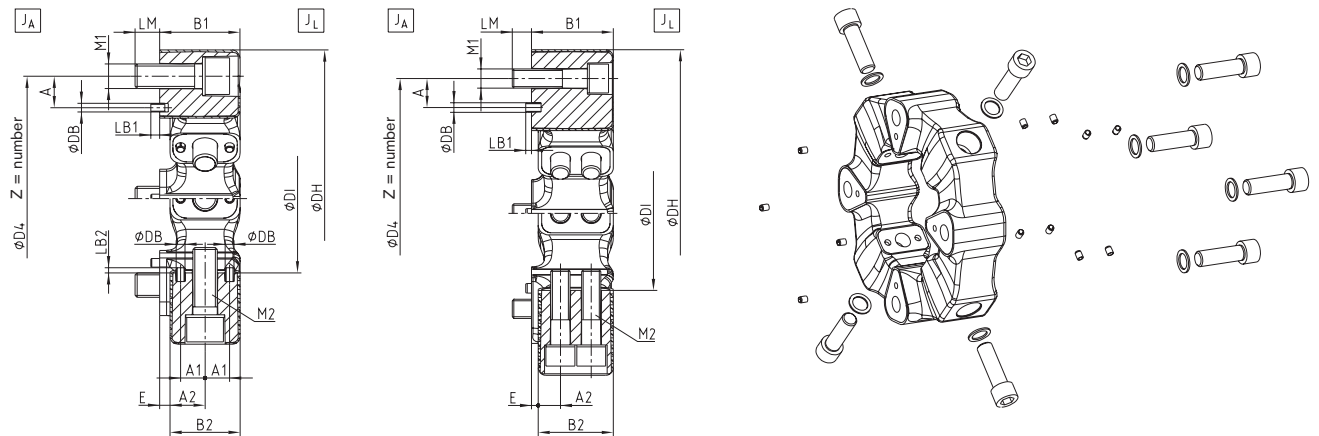

EVOLASTIC® type E																		
Size	Dimensions [mm]															Mass moment of inertia [kgm ²] ¹⁾		Weight [kg] ¹⁾
	DH	DI	B1	B2	E	D4	Z x Pitch	A	LM	LB1	DB	A1	A2	LB2	JA	JL		
12	122	60	32	28	4	100	3 x 120°	12	10	4	4	10	14	-	0.0005	0.0005	0.50	
24	150	70	42	36	6	125	3 x 120°	18	12	4	5	13.5	18	5	0.0010	0.0010	0.93	
48	170	85	46	40	6	140	4 x 90°	18	14	5	5	14	20	5	0.0040	0.0030	1.55	
60	200	100	58	50	8	165	3 x 120°	20	16	5	5	18	25	5	0.0070	0.0070	2.28	
86	200	100	58	50	8	165	4 x 90°	20	16	5	5	18	25	5	0.0090	0.0080	2.76	
125	260	125	70	63	7	215	3 x 120°	25	20	5	8	22.5	31.5	5	0.0240	0.0220	4.74	
200	260	125	70	63	7	215	4 x 90°	25	20	5	8	22.5	31.5	5	0.0300	0.0280	5.79	
280	300	145	80	72	8	250	4 x 90°	25	20	5	8	22.5	36	5	0.0550	0.0500	7.89	
360	340	160	85	78	7	280	4 x 90°	30	20	6	10	-	2 x 23	-	0.0960	0.0950	11.50	
560	363	170	105	95	10	300	4 x 90°	40	24	6	10	-	2 x 28.5	-	0.1510	0.1450	15.38	

¹⁾ With max. bore

Delivery condition:

EVOLASTIC® couplings type E are supplied with a mounting kit consisting of cap screws, screw locking washers and positioning sleeves. With the connection design make sure sufficient screw-in depth.

Size	Cap screw DIN EN ISO 4762 - 12.9		Tightening torque TA [Nm]
	M1 / axial	M2 / radial	
12	M10 x 30	M10 x 30	71
24	M12 x 35	M12 x 35	123
48	M14 x 40	M14 x 40	195
60	M16 x 50	M16 x 50	302
86	M16 x 50	M16 x 50	302
125	M20 x 65	M20 x 65	592
200	M20 x 65	M20 x 65	592
280	M20 x 65	M20 x 65	592
360	M20 x 80	M20 x 80	592
560	M20 x 90	M24 x 90	592 / 1,017

Ordering example:	EVOLASTIC® 48	E	S
		Coupling size	Type

EVOLASTIC® EH

Highly flexible couplings

Individual element + shaft connection

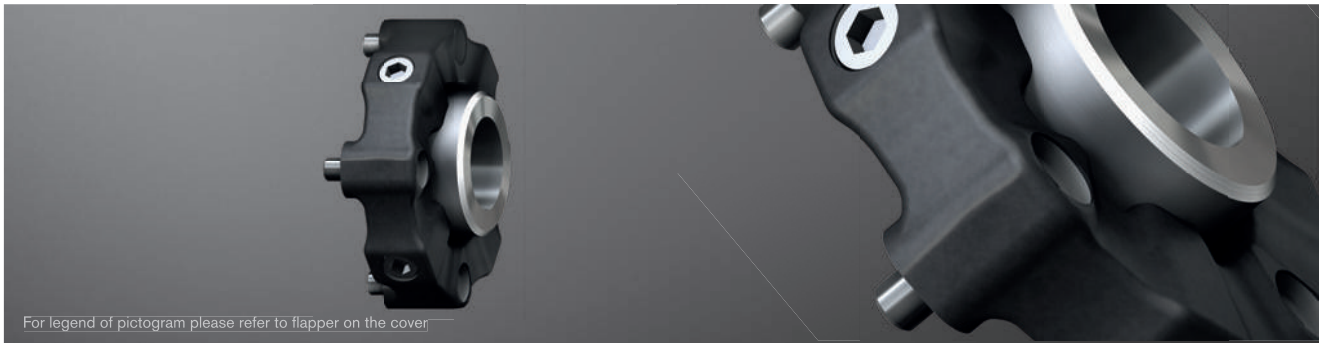

For legend of pictogram please refer to flapper on the cover



Components

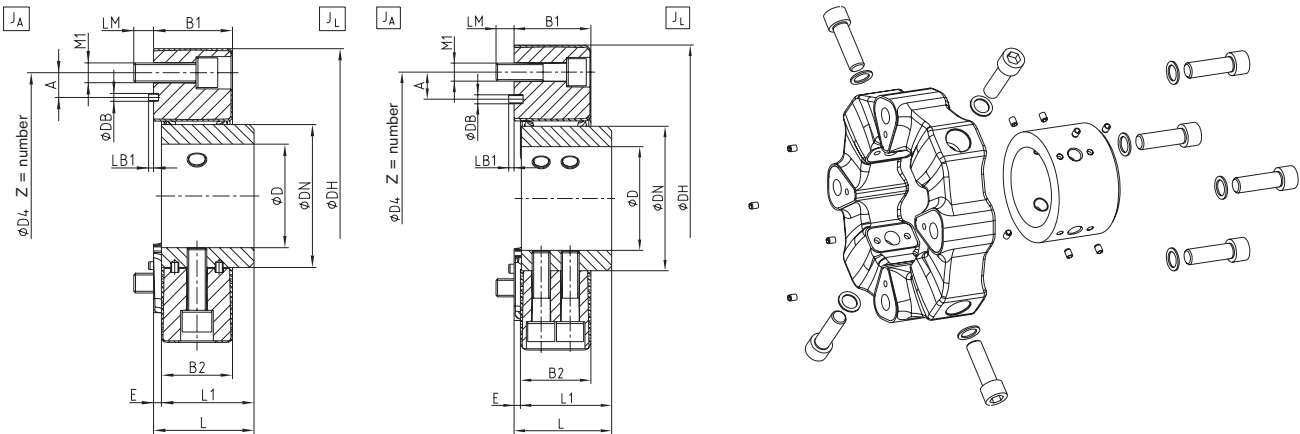

EVOLASTIC® type EH																		
Size	Dimensions [mm]															Mass moment of inertia [kgm ²] ¹⁾		Weight [kg] ¹⁾
	DH	D ¹⁾	DN	B1	B2	E	L	L1	D4	Z x Pitch	M1	A	LM	LB1	DB	J _A	J _L	
12	122	38	60	32	28	4	46	42	100	3 x 120°	M10	12	10	4	4	0.0006	0.0009	1.04
24	150	48	70	42	36	6	56	50	125	3 x 120°	M12	18	12	4	5	0.0020	0.0020	1.70
48	170	55	85	46	40	6	61	55	140	4 x 90°	M14	18	14	5	5	0.0040	0.0050	2.90
60	200	65	100	58	50	8	74	66	165	3 x 120°	M16	20	16	5	5	0.0070	0.0110	4.55
86	200	65	100	58	50	8	74	66	165	4 x 90°	M16	20	16	5	5	0.0090	0.0120	5.03
125	257	85	125	70	63	8	88	80	215	3 x 120°	M20	25	20	5	8	0.0240	0.0340	8.77
200	257	85	125	70	63	8	88	80	215	4 x 90°	M20	25	20	5	8	0.0300	0.0400	9.80
280	299	105	145	80	72	8	102	94	250	4 x 90°	M20	25	20	5	8	0.0560	0.0730	13.54
360	340	115	160	85	78	8	108	100	280	4 x 90°	M20	30	20	6	10	0.0960	0.1320	18.85
560	363	120	170	105	95	10	135	125	300	4 x 90°	M24	40	24	6	10	0.1530	0.2080	26.34

¹⁾ With max. bore

Ordering example:	EVOLASTIC® 48	EH	S	1.0	Ø52
	Coupling size	Type	Elastomer hardness	Hub type	Finish bore

EVOLASTIC® E2H

Highly flexible couplings

Shaft-to-shaft connection

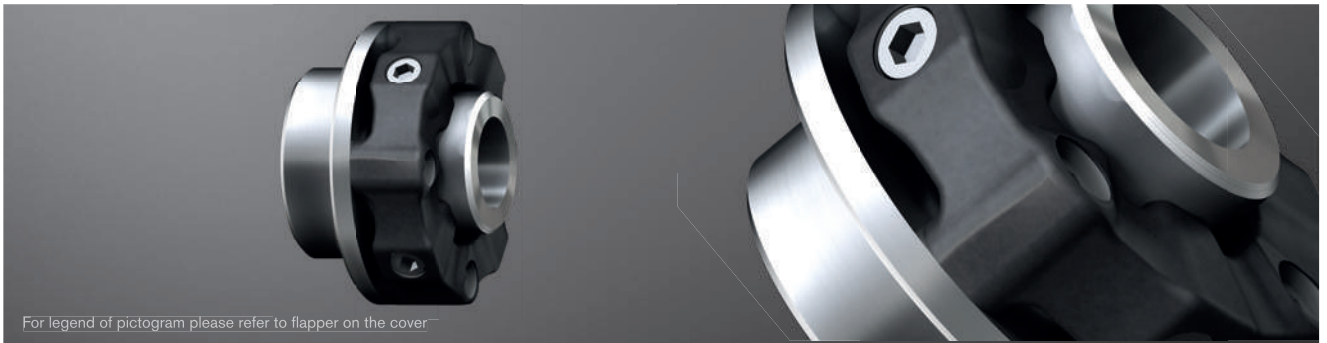

For legend of pictogram please refer to flapper on the cover

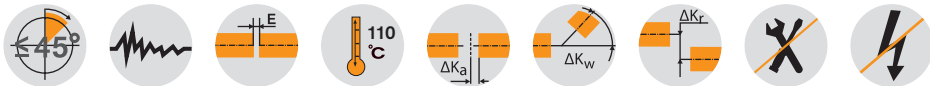

Components

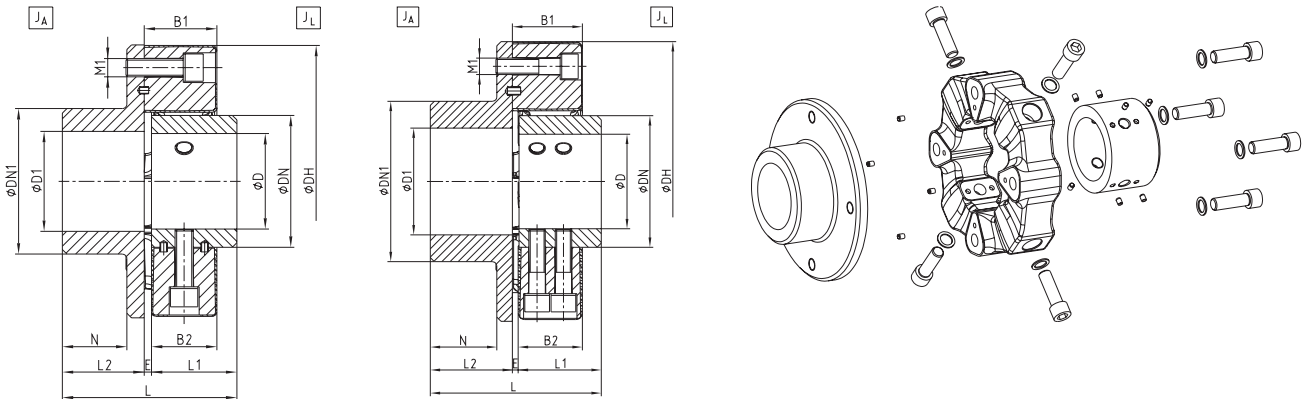

EVOLASTIC® type E2H																	
Size	Dimensions [mm]														Mass moment of inertia [kgm ²] ¹⁾		Weight [kg] ¹⁾
	DH	D ¹⁾	DN	D1 ¹⁾	DN1	B1	B2	E	N	L	L1	L2	M1	JA	JL		
12	122	38	60	55	80	32	28	4	32	88	42	42	M10	0.0030	0.0010	2.38	
24	150	48	70	70	100	42	36	6	38	106	50	50	M12	0.0080	0.0020	4.16	
48	170	55	85	85	115	46	40	6	41	116	55	55	M14	0.0160	0.0050	6.21	
60	200	65	100	100	140	58	50	8	50	140	66	66	M16	0.0360	0.0110	10.39	
86	200	65	100	100	140	58	50	8	50	140	66	66	M16	0.0370	0.0120	10.83	
125	260	85	125	110	160	70	63	8	60	168	80	80	M20	0.1110	0.0340	20.17	
200	260	85	125	110	160	70	63	8	60	168	80	80	M20	0.1160	0.0400	21.15	
280	300	105	145	110	160	80	72	8	70	192	94	90	M20	0.1960	0.0730	28.30	
360	340	115	160	130	195	85	78	8	80	208	100	100	M20	0.3540	0.1320	40.66	
560	370	120	170	140	200	105	95	10	100	260	125	125	M24	0.5890	0.2080	56.56	

¹⁾ With max. bore

Ordering example:	EVOLASTIC® 48	E2H	S	1.0	Ø52	1.0	Ø52
	Coupling size	Type	Elastomer hardness	Hub type	Finish bore	Hub type	Finish bore

EVOLASTIC® EFH

Highly flexible couplings

Flange-to-shaft connection



For legend of pictogram please refer to flapper on the cover



Components

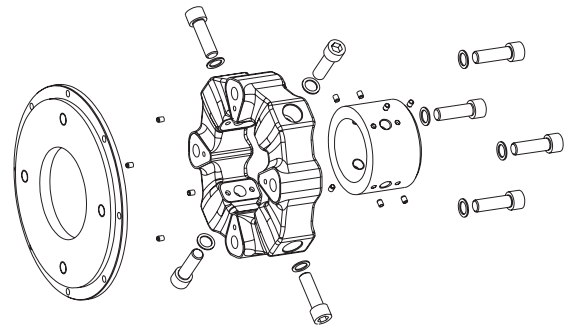
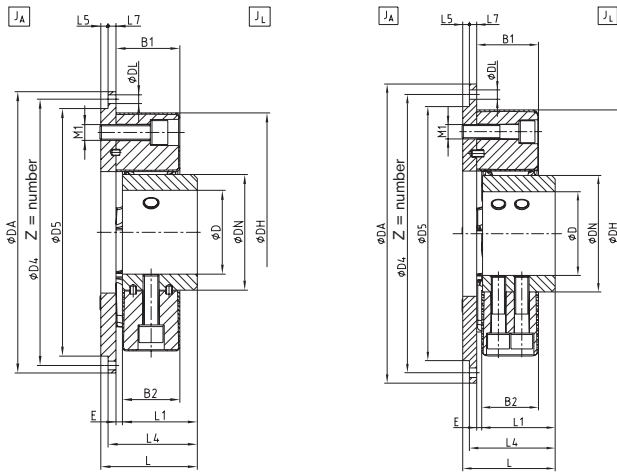

Flange dimensions according to SAE J620 [mm]				
Size	DA	D4	Z	DL
6 1/2"	215.90	200.02	6	9
7 1/2"	241.30	222.25	8	9
8"	263.52	244.47	6	11
10"	314.32	295.27	8	11
11 1/2"	352.42	333.37	8	11
14"	466.72	438.15	8	13

EVOLASTIC® type EFH																							
Size	Flange connection acc. to SAE - J620						Dimensions [mm]											Mass moment of inertia [kgm ²] ¹⁾		Weight [kg] ¹⁾			
	6.5"	7.5"	8"	10"	11.5"	14"	DH	D ¹⁾	DN	B1	B2	E	L	L1	L4	L5	L7	M1	D5		J _A	J _L	
12	●						122	38	60	32	28	4	56	42	52	4	6	M10	180	0.013	0.001	3.26	
		●																	190	0.020	0.001	3.78	
24	●						150	48	70	42	36	6	68	50	62	6	6	M12	180	0.016	0.002	4.20	
		●																	190	0.023	0.002	4.77	
48		●					170	55	85	46	40	6	75	55	67	8	6	M14	190	0.026	0.005	6.03	
			●												71	4	10		200	0.034	0.005	6.62	
60			●				200	65	100	58	50	8	90	66	84	6	10	M16	260	0.091	0.005	9.91	
				●															270	0.103	0.011	12.07	
86				●			200	65	100	58	50	8	90	66	84	6	10	M16	310	0.165	0.011	14.49	
					●														270	0.105	0.012	12.52	
125					●		260	85	125	70	63	8	107	80	98	9	10	M16	360	0.166	0.012	14.94	
						●													270	0.129	0.034	16.72	
200						●	260	85	125	70	63	8	107	80	98	9	10	M16	310	0.199	0.034	19.57	
																			270	0.135	0.039	17.64	
280							300	105	145	80	72	8	121	94	112	9	10	M20	405	0.205	0.039	20.50	
																			405	0.572	0.039	30.01	
360							340	115	160	85	78	8	127	100	118	9	10	M20	310	0.226	0.072	23.54	
																			405	0.593	0.072	33.05	
560							363	120	170	105	95	10	160	125	145	15	25	M24	405	0.628	0.130	37.55	
																			405	0.794	0.203	49.06	

¹⁾ With max. bore

Ordering example:	EVOLASTIC® 48	EFH	S	8	1.0	Ø52
	Coupling size	Type	Elastomer hardness	Flange ØDA acc. to SAE or special	Hub type	Finish bore

EVOLASTIC® EP

Highly flexible couplings

Pluggable elastomer - available in various kinds of Shore hardness



For legend of pictogram please refer to flapper on the cover



Components

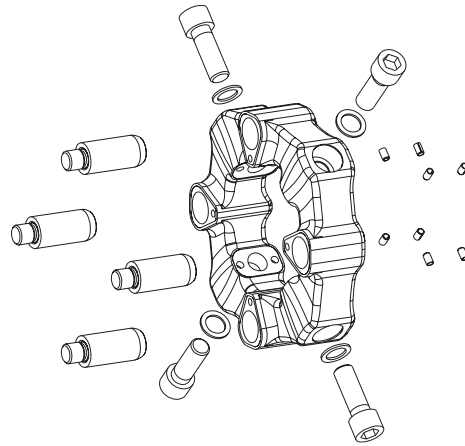
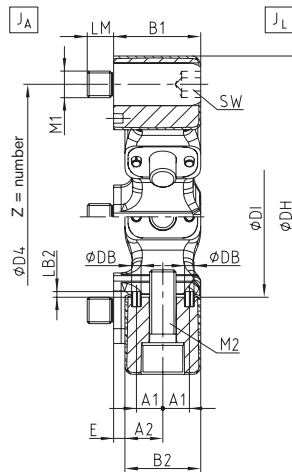

EVOLASTIC® type EP																
Size	Dimensions [mm]												Mass moment of inertia [kgm ²] ¹⁾		Weight [kg] ¹⁾	
	DH	DI	B1	B2	E	D4	Z x Pitch	LM	DB	A1	A2	LB2	JA	JL		
12	122	60	32	28	4	100	3 x 120°	10	4	10	14	-	0.001	0.001	0.55	
24	150	70	42	36	6	125	3 x 120°	12	5	13.5	18	5	0.002	0.001	1.03	
48	170	85	46	40	6	140	4 x 90°	14	5	14	20	5	0.005	0.003	1.74	
60	200	100	58	50	8	165	3 x 120°	16	5	18	25	5	0.009	0.007	1.52	
86	200	100	58	50	8	165	4 x 90°	16	5	18	25	5	0.010	0.008	3.08	
125	260	125	70	63	7	215	3 x 120°	20	8	22.5	31.5	5	0.028	0.022	5.16	
200	260	125	70	63	7	215	4 x 90°	20	8	22.5	31.5	5	0.036	0.028	6.35	
280	On request															
360	On request															
560	On request															

¹⁾ With max. bore

Delivery condition:

EVOLASTIC® couplings type EP are supplied with a mounting kit consisting of cap screws, screw locking washers, locking pins and positioning sleeves. With the connection design make sure sufficient screw-in depth. For the locking pin provide for an adhesive (e. g. Loctite® 243).

Size	Pin		Cap screw radial DIN EN ISO 4762 - 12.9		
	M1 / axial	Tightening torque [Nm]	M2 / radial	SW	Tightening torque [Nm]
12	M10	71	M10 x 30	8	71
24	M12	123	M12 x 35	10	123
48	M14	195	M14 x 40	12	195
60	M16	302	M16 x 50	14	302
86	M16	302	M16 x 50	14	302
125	M20	592	M20 x 65	17	592
200	M20	592	M20 x 65	17	592

Ordering example:	EVOLASTIC® 48	EP	S
	Coupling size	Type	Elastomer hardness

EVOLASTIC® EHP

Highly flexible couplings

Pluggable elastomer + shaft connection



For legend of pictogram please refer to flapper on the cover



Components

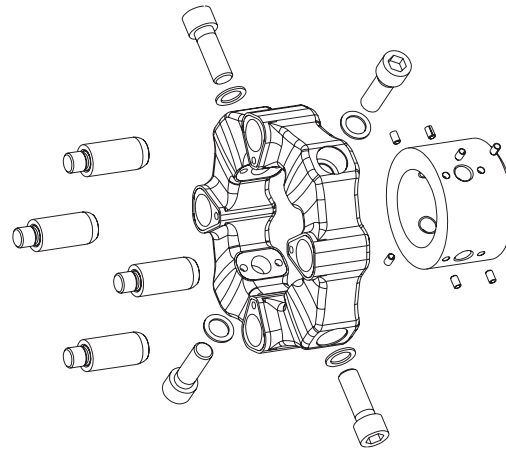
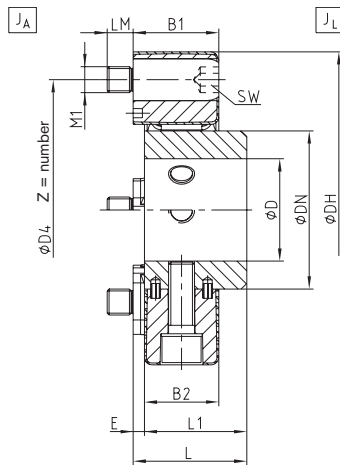

EVOLASTIC® type EHP																		
Size	Dimensions [mm]															Mass moment of inertia [kgm ²] ¹⁾		Weight [kg] ¹⁾
	DH	DN	D	B1	B2	E	L	L1	LM	LB	DB	D4	Z x Pitch	M1	SW	JA	JL	
12	122	60	38	32	28	4	46	42	10	4	4	100	3 x 120°	M10	8	0.001	0.001	1.09
24	150	70	48	42	36	6	56	50	12	4	5	125	3 x 120°	M12	10	0.002	0.002	1.80
48	170	85	55	46	40	6	61	55	14	5	5	140	4 x 90°	M14	12	0.004	0.005	3.07
60	200	100	65	58	50	8	74	66	16	5	5	165	3 x 120°	M16	14	0.009	0.010	4.79
86	200	100	65	58	50	8	74	66	16	5	5	165	4 x 90°	M16	14	0.010	0.012	5.32
125	260	125	85	70	63	8	88	80	20	5	8	215	3 x 120°	M20	17	0.028	0.024	9.15
200	260	125	85	70	63	8	88	80	20	5	8	215	4 x 90°	M20	17	0.036	0.039	10.30
280	On request																	
360																		
560																		

¹⁾ With max. bore

Ordering example:	EVOLASTIC® 48	EHP	S	1.0	Ø52
	Coupling size	Type	Elastomer hardness	Hub type	Finish bore

EVOLASTIC® E2HP

Highly flexible couplings

Shaft-to-shaft connection, plug-in



For legend of pictogram please refer to flapper on the cover



Components

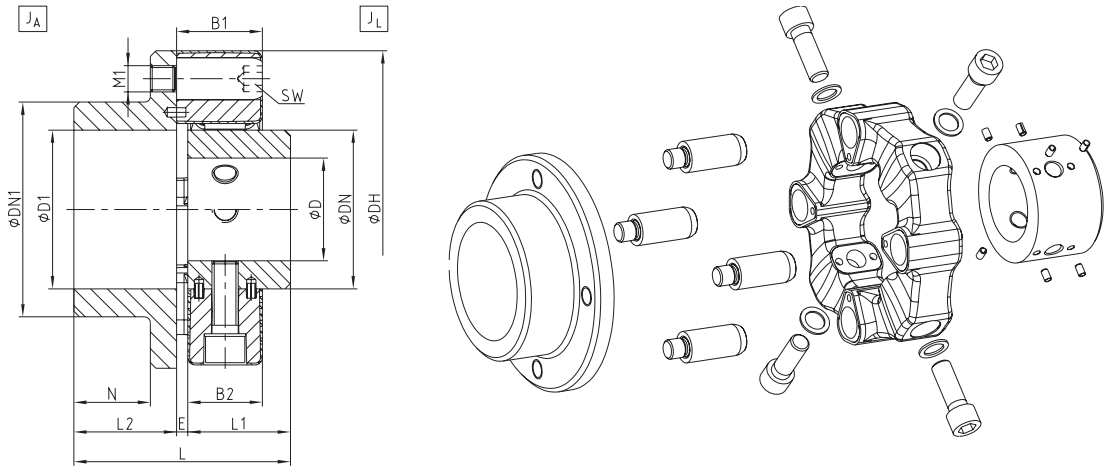

EVOLASTIC® type E2HP																	
Size	Dimensions [mm]														Mass moment of inertia [kgm ²] ¹⁾		Weight [kg] ¹⁾
	DH	DN	D	DN1	D1	B1	B2	E	N	L	L1	L2	M1	SW	J _A	J _L	
12	122	60	38	80	55	32	28	4	32	88	42	42	M10	8	0.003	0.001	2.44
24	150	70	48	100	70	42	36	6	38	106	50	50	M12	10	0.009	0.002	4.26
48	170	85	55	115	85	46	40	6	41	116	55	55	M14	12	0.016	0.005	6.41
60	200	100	65	140	100	58	50	8	50	140	66	66	M16	14	0.038	0.010	10.62
86	200	100	65	140	100	58	50	8	50	140	66	66	M16	14	0.039	0.012	11.13
125	260	125	85	160	110	70	63	8	60	168	80	80	M20	17	0.115	0.034	20.55
200	260	125	85	160	110	70	63	8	60	168	80	80	M20	17	0.123	0.039	21.65
280	On request																
360																	
560																	

¹⁾ With max. bore

Ordering example:	EVOLASTIC® 48	E2HP	S	1.0	Ø52	1.0	Ø52
	Coupling size	Type	Elastomer hardness	Hub type	Finish bore	Hub type	Finish bore

EVOLASTIC® EFHP

Highly flexible couplings

Flange-to-shaft connection, pluggable



For legend of pictogram please refer to flapper on the cover



Components

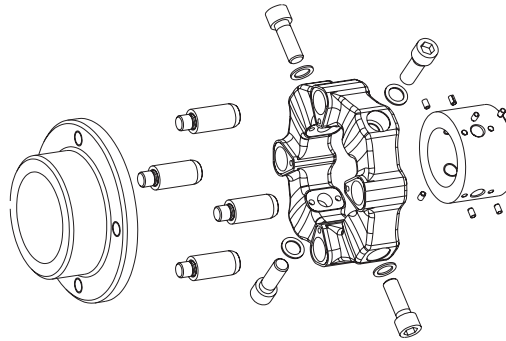
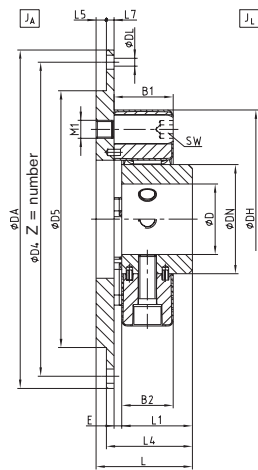

Flange dimensions according to SAE J620 [mm]				
Size	DA	D4	Z	DL
6 1/2"	215.90	200.02	6	9
7 1/2"	241.30	222.25	8	9
8"	263.52	244.47	6	11
10"	314.32	295.27	8	11
11 1/2"	352.42	333.37	8	11
14"	466.72	438.15	8	13

EVOLASTIC® type EFHP																									
Size	Flange connection acc. to SAE - J620						Dimensions [mm]													Mass moment of inertia [kgm ²] ¹⁾		Weight [kg] ¹⁾			
	6.5"	7.5"	8"	10"	11.5"	14"	D5	DH	DN	D	B1	B2	L5	L7	E	L4	L	L1	M1	SW	J _A		J _L		
12	●						180	122	60	38	32	28	4	6	4	52	56	42	M10	8	0.014	0.001	3.33		
		●					190														0.020	0.001	3.84		
24	●						180	150	70	48	42	36	6	6	6	62	68	50	M12	10	0.016	0.002	4.30		
		●					190														0.229	0.002	4.86		
48		●					190	170	85	55	46	40	8	6	6	67	75	55	M14	12	0.027	0.005	6.20		
			●				200														0.035	0.005	6.80		
60			●				260	200	100	65	58	50	4	10	8	84	90	66	M16	14	0.091	0.005	10.09		
				●			270														0.105	0.011	12.30		
86				●			310	200	100	65	58	50	6	10	8	84	90	66	M16	14	0.166	0.011	14.73		
					●		270														0.107	0.012	12.82		
125					●		310	260	125	85	70	63	9	10	8	98	107	80	M20	17	0.168	0.012	15.24		
						●	270														0.134	0.034	17.10		
200						●	310	260	125	85	70	63	9	10	8	98	107	80	M20	17	0.204	0.034	19.95		
						●	405														0.141	0.039	18.20		
280																						0.212	0.039	21.06	
360																							0.578	0.039	30.57
560																									
On request																									

¹⁾ With max. bore

Ordering example:	EVOLASTIC® 48	EFHP	S	8	67	1.0	Ø55
	Coupling size	Type	Elastomer hardness	Flange ØDA acc. to SAE or special	Mounting length LC1	Hub type	Finish bore

EVOLASTIC® D2H

Highly flexible couplings

Double-cardanic shaft-to-shaft connection



For legend of pictogram please refer to flapper on the cover



Components

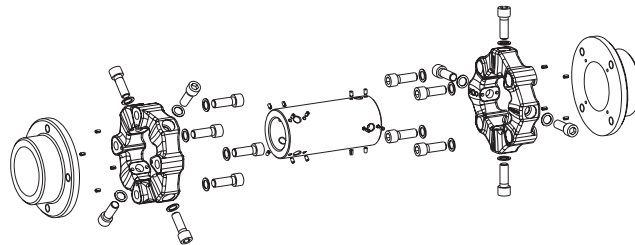
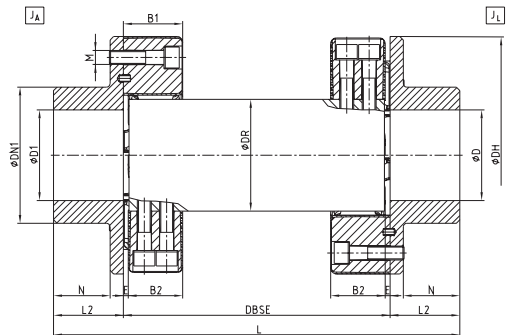
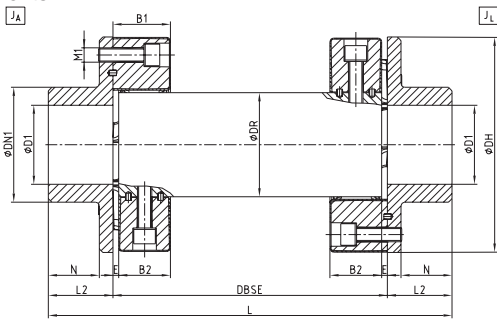

EVOLASTIC® type D2H												
Size	Dimensions [mm]										Mass moment of inertia [kgm ²] ¹⁾	
	DH	DN1	D1	DR	B1	B2	E	L2	N	M1	JA	JL
12	122	80	55	60	32	28	4	42	32	M10	0.0030	0.0030
24	150	100	70	70	42	36	6	50	38	M12	0.0080	0.0080
48	170	115	85	85	46	40	6	55	41	M14	0.0160	0.0160
60	200	140	100	100	58	50	8	66	50	M16	0.0360	0.0360
86	200	140	100	100	58	50	8	66	50	M16	0.0370	0.0370
125	260	160	110	125	70	63	8	80	60	M20	0.1110	0.1110
200	260	160	110	125	70	63	8	80	60	M20	0.1160	0.1160
280	300	160	110	145	80	72	8	94	70	M20	0.1960	0.1960
360	340	195	130	160	85	78	8	100	80	M20	0.3540	0.3540
560	370	200	140	170	105	95	10	125	100	M24	0.5890	0.5890

Dimension L and E1 as well as mass moment of inertia of intermediate shaft and total weight depend on the mounting length

¹⁾ With max. bore

Ordering example:	EVOLASTIC® 48	D2H	140	S	1.0	Ø52	1.0	Ø52
	Coupling size	Type	Shaft distance DBSE	Elastomer hardness	Hub type	Finish bore	Hub type	Finish bore

EVOLASTIC® DFH

Highly flexible couplings

Double-cardanic flange-to-shaft connection



For legend of pictogram please refer to flapper on the cover



Components

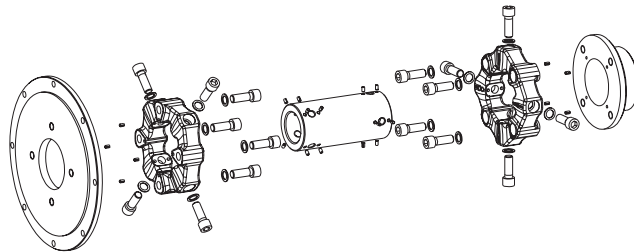
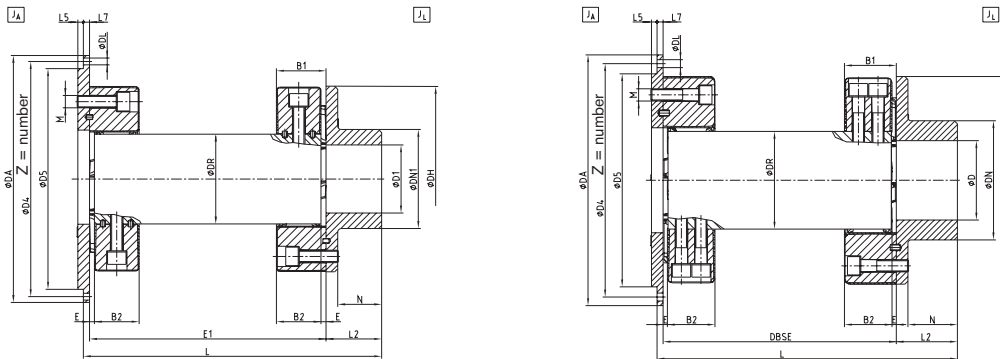

Flange dimensions according to SAE J620 [mm]				
Size	DA	D4	Z	DL
6 1/2"	215.90	200.02	6	9
7 1/2"	241.30	222.25	8	9
8"	263.52	244.47	6	11
10"	314.32	295.27	8	11
11 1/2"	352.42	333.37	8	11
14"	466.72	438.15	8	13

EVOLASTIC® type DFH																					
Size	Flange connection acc. to SAE - J620					Dimensions [mm]														Mass moment of inertia [kgm ²] ¹⁾	
	6.5"	7.5"	8"	10"	11.5"	14"	D5	DH	DN1	D1	DR	B1	B2	E	L5	L7	L2	N	M	J _A	J _L
12	●						180	122	80	55	60	32	28	4	4	6	42	32	M10	0.013	0.003
		●					190													0.020	
24	●						180	150	100	70	70	42	36	6	6	6	50	38	M12	0.016	0.008
		●					190													0.023	
48		●					190	170	115	85	85	46	40	6	8	6	55	41	M14	0.026	0.016
			●				200													0.034	
60			●				260	200	140	100	100	58	50	8	6	10	66	50	M16	0.091	0.036
				●			270													0.103	
86				●			310	200	140	100	100	58	50	8	6	10	66	50	M16	0.165	0.037
					●		270													0.105	
125					●		310	260	160	110	125	70	63	8	9	10	80	60	M20	0.166	0.111
						●	270													0.129	
200						●	310	260	160	110	125	70	63	8	9	10	80	60	M20	0.199	0.116
							270													0.135	
280						●	405	300	160	110	145	80	72	8	9	10	94	70	M20	0.205	0.196
							310													0.226	
360						●	405	340	195	130	160	85	78	8	9	10	100	80	M20	0.572	0.354
							405													0.593	
560						●	405	370	200	140	170	105	95	10	15	25	125	100	M24	0.628	0.589
							405													0.794	

Dimension L and E1 as well as mass moment of inertia of intermediate shaft and total weight depend on the mounting length
¹⁾ With max. bore

Ordering example:	EVOLASTIC® 48	DFH	140	S	8	1.0	Ø52
	Coupling size	Type	Shaft distance DBSE	Elastomer hardness	Flange ØDA acc. to SAE or special	Hub type	Finish bore

KTR Germany:

Headquarters:

KTR Systems GmbH
Carl-Zeiss-Straße 25
D-48432 Rheine
Phone: +49 5971 798-0
Fax: +49 5971 798-698 or 798-450
E-mail: mail@ktr.com
Internet: www.ktr.com

KTR Brake Systems GmbH

Competence Center for Brake Systems
Zur Brinke 14
D-33758 Schloß Holte-Stukenbrock
Phone: +49 5207 99161-0
Mobile: +49 175 2650033
Fax: +49 5207 99161-11

Leiter Vertrieb Bremsen Wind

Jörn Edzards, Dipl.-Ing. (FH)
Zur Brinke 14
D-33758 Schloß Holte-Stukenbrock
Phone: +49 5207 99161-0
Mobile: +49 175 2650033
E-mail: j.edzards@ktr.com

Leiter Vertrieb Bremsen Industrie

Thomas Wienkotte, Dipl.-Ing. (FH)
Peter-Schumacher-Straße 102
D-50171 Kerpen
Phone: +49 2237 971796
Mobile: +49 172 5859448
E-mail: t.wienkotte@ktr.com

Außendienst Norddeutschland für Hydraulik-Komponenten

Gunnar Ehlers
Finkenstieg 4b
21629 Neu Wulmstorf
Mobile: +49 174 3301536
E-mail: g.ehlers@ktr.com

Außendienst Bayern, Baden-Württemberg und Österreich für Hydraulik-Komponenten

Klaus-Peter Sprödhuber
Hussengutstr. 55
95445 Bayreuth
Phone: +49 921 16388991
Mobile: +49 172 1096496
E-mail: k.sproedhuber@ktr.com

Schleswig-Holstein, Nord-Niedersachsen, Hamburg, Bremen

Martin Lau, Maschinenbautechniker
KTR Ingenieurbüro Hamburg
Geschwister-Scholl-Allee 44
25524 Itzehoe
Phone: +49 4821 4050812
Mobile: +49 172 5310014
E-mail: m.lau@ktr.com

NRW: Großraum Düsseldorf, Köln, Aachen

John Rischmüller,
B. Sc. Wirtschaftsingenieurwesen
KTR Ingenieurbüro Hilden
Walder Str. 53
40724 Hilden
Mobile: +49 151 62489605
E-mail: j.rischmueller@ktr.com

Emsland, Mitte- und Süd-Niedersachsen, Ostwestfalen

Rainer Lüttmann
KTR Systems GmbH
Carl-Zeiss-Straße 25
48432 Rheine
Phone: +49 5971 798-340
Mobile: +49 172 5322164
E-mail: r.luettmann@ktr.com

Siegerland

René Szabó, Maschinenbautechniker
Waldstr. 67
57080 Siegen-Niederschelden
Phone: +49 5971 798 7777
Mobile: +49 175 81 64 844
E-mail: r.szabo@ktr.com

Ruhrgebiet, Hessen-Nord

René Pottmann, Maschinenbautechniker
KTR Ingenieurbüro Dortmund
Lindemannstraße 9
44137 Dortmund
Phone: +49 231 91259060
Mobile: +49 162 2186045
E-mail: r.pottmann@ktr.com

Hessen, Rheinland-Pfalz, Saarland

Martin Dietrich, Ingenieur Maschinenbau
KTR Ingenieurbüro Frankfurt
Schorbachstr. 9
35510 Butzbach
Phone: +49 6033 9248494
Mobile: +49 172 5329968
E-mail: m.dietrich@ktr.com

Berlin, Mecklenburg-Vorpommern Südost, Sachsen-Anhalt, Brandenburg

Thüringen Nord, Sachsen
Norman Schlag, Tech. BW (IHK)
KTR Ingenieurbüro Leipzig
Hauptstraße 101
04416 Markkleeberg
Phone: +49 341 35416467
Mobile: +49 173 4716266
E-mail: n.schlag@ktr.com

Baden-Württemberg Nord

Eberhard Maier, Dipl.-Ing. (FH)
Hortensienweg 1
70374 Stuttgart, Sommerain
Phone: +49 71 16 5842957
Mobile: +49 172 5355056
E-mail: e.maier@ktr.com

Baden-Württemberg Süd

Jochen Glöckler, Maschinenbautechniker
KTR Ingenieurbüro Balingen
Hölzlestraße 44
72336 Balingen
Phone: +49 7433 91381
Mobile: +49 172 5310049
E-mail: j.gloeckler@ktr.com

Bayern-Nord, Thüringen Süd

Alexander Ennulat, Dipl.-Ing.
KTR Ingenieurbüro Römerstein
Grabenstetter Str. 28
72587 Römerstein
Phone: +49 7382 9369226
Mobile: +49 162 4160354
E-mail: a.ennulat@ktr.com

Bayern-Süd, Baden-Württemberg Ost

Peter Benkard, Dipl.-Ing. (FH)
KTR Ingenieurbüro Adelsried
Am Mittelfeld 13
86477 Adelsried
Phone: +49 8293 9605-04
Mobile: +49 172 5313059
E-mail: p.benkard@ktr.com

For all representatives and sales partners please refer to www.ktr.com.

KTR worldwide:

Algeria

KTR Algérie
Algeria Business Center -
Pins Maritimes
DZ-16130 Alger Mohammadia
Phone: +213 661 92 24 00
E-mail: ktr-dz@ktr.com

Brazil

KTR do Brasil Ltda.
Rua Jandaia do Sul 471 -
Bairro Emiliano Perneta
Pinhais - PR - Cep: 83324-040
Phone: +55 41 36 69 57 13
E-mail: ktr-br@ktr.com

Chile

KTR Systems Chile SpA
Calle Bucarest 17
Oficina 33 Providencia
Santiago de Chile
Phone: +56 23 22 46 674
Mobile: +56 9 44 75 57 02
E-mail: ktr-cl@ktr.com

China

KTR Power Transmission Technology
(Shanghai) Co. Ltd.
Building 1005, ZOBON Business Park
999 Wangqiao Road
Pudong
Shanghai 201201
Phone: +86 21 58 38 18 00
Fax: +86 21 58 38 19 00
E-mail: ktr-cn@ktr.com

Czech Republic

KTR CR, spol. s r.o.
Brněnská 559
569 43 Jevíčko
Czech Republic
Phone: +420 461 325 014
E-mail: ktr-cz@ktr.com

Denmark

KTR Systems Danmark ApS
Vejlsovej 51, Bygning N
8600 Silkeborg
Phone: +45 39 39 10 50
E-mail: ktr-dk@ktr.com

Finland

KTR Finland OY
Tiistiniityntie 4
SF-02230 Espoo
Phone: +358 2 07 41 46 10
Fax: +358 2 07 41 46 19
E-mail: ktr-fi@ktr.com

France

KTR France SAS
5 Chemin de la Brocardière
CS 71359
F-69573 DARDILLY CEDEX
Phone: +33 4 78 64 55 26
Fax: +33 4 78 64 54 31
E-mail: ktr-fr@ktr.com

India

KTR Couplings (India) Pvt. Ltd.,
T-36 / 37 / 38, MIDC Bhosari
Pune 411026
Phone: +91 20 27 12 73 24
Fax: +91 20 27 12 73 23
E-mail: ktr-in@ktr.com

Italy

KTR Systems GmbH
Sede Secondaria Italia
Via Giovanni Brodolini, 8
I - 40133 Bologna (BO)
Phone: +39 051 613 32 32
Fax: +39 051 298 55 77
E-mail: ktr-it@ktr.com

Japan

KTR Japan Co., Ltd.
Toei Bldg.2F, 6-1-8 Motomachi-dori
Chuo-ku, Kobe
650-0022 Japan
Phone: +81 7 89 54 65 70
Fax: +81 7 89 54 65 75
E-mail: ktr-jp@ktr.com

Korea

KTR Korea Ltd.
#604, Songwon bldg., 89-10, Gal-
maejungang-ro, Guri-si, Gyeonggi-do,
11901 Korea
Phone: +82 3 15 69 45 10
Fax: +82 3 15 69 45 25
E-mail: ktr-kr@ktr.com

Netherlands

KTR Benelux B. V.
Postbus 87
Oosterveldsingel 3
NL-7558 PJ Hengelo (O)
Phone: +31 74 2553680
Fax: +31 74 2553689
E-mail: ktr-nl@ktr.com

Norway

KTR Systems Norge AS
Lahaugmoveien 81
N-2013 Skjetten
Phone: +47 64 83 54 90
Fax: +47 64 83 54 95
E-mail: ktr-no@ktr.com

Poland

KTR Polska Sp. z o.o.
ul. Czerwone Maki 65
PL-30-392 Kraków
Phone: +48 12 267 28 83
Fax: +48 12 267 07 66
E-mail: ktr-pl@ktr.com

Russia

KTR RUS LLC
6 Verhnii Pereulok 12
Litera A, Office 229
194292 St. Petersburg
Phone: +7 812 383 51 20
Fax: +7 812 383 51 25
E-mail: ktr-ru@ktr.com
Internet: www.ktr.ru

South Africa

KTR Couplings SA (Pty) Ltd.
28 Spartan Road, Kempton Park,
Spartan Ext. 21
Phone: +27 11 281 3801
Fax: +27 11 281 3812
E-mail: ktr-za@ktr.com

Spain

KTR Systems GmbH
Estartetxe, n° 5-Oficina 322
E-48940 Leioa (Vizcaya)
Phone: +34 9 44 80 39 09
Fax: +34 9 44 31 68 07
E-mail: ktr-es@ktr.com

Sweden

KTR Sverige AB
Box 7010
S-187 11 Täby
Phone: +46 86 25 02 90
E-mail: info.se@ktr.com

Switzerland

KTR Systems Schweiz AG
Bahnstr. 60
CH-8105 Regensdorf
Phone: +41 4 33 11 15 48
Fax: +41 4 33 11 15 56
E-mail: ktr-ch@ktr.com

Taiwan

KTR Taiwan Ltd.
No.: 30-1, 36 Rd
Taichung Industry Zone
Taichung City
407 Taiwan (R. O. C.)
Phone: +886 4 23 59 32 78
Fax: +886 4 23 59 75 78
E-mail: ktr-tw@ktr.com

Turkey

KTR Turkey
Güç Aktarma Sistemleri San. ve Tic. Ltd.
Şti.
Kayışdağı Cad. No: 117/2
34758 Atasehir -Istanbul
Phone: +90 216 574 37 80
Fax: +90 216 574 34 45
E-mail: ktr-tr@ktr.com

United Kingdom

KTR U.K. Ltd.
Robert House
Unit 7, Acorn Business Park
Woodseats Close
Sheffield
United Kingdom, S8 0TB
Phone: +44 11 42 58 77 57
Fax: +44 11 42 58 77 40
E-mail: ktr-uk@ktr.com

USA

KTR Corporation
122 Anchor Road
Michigan City, Indiana 46360
Phone: +1 219 8 72 91 00
Fax: +1 219 8 72 91 50
E-mail: ktr-us@ktr.com

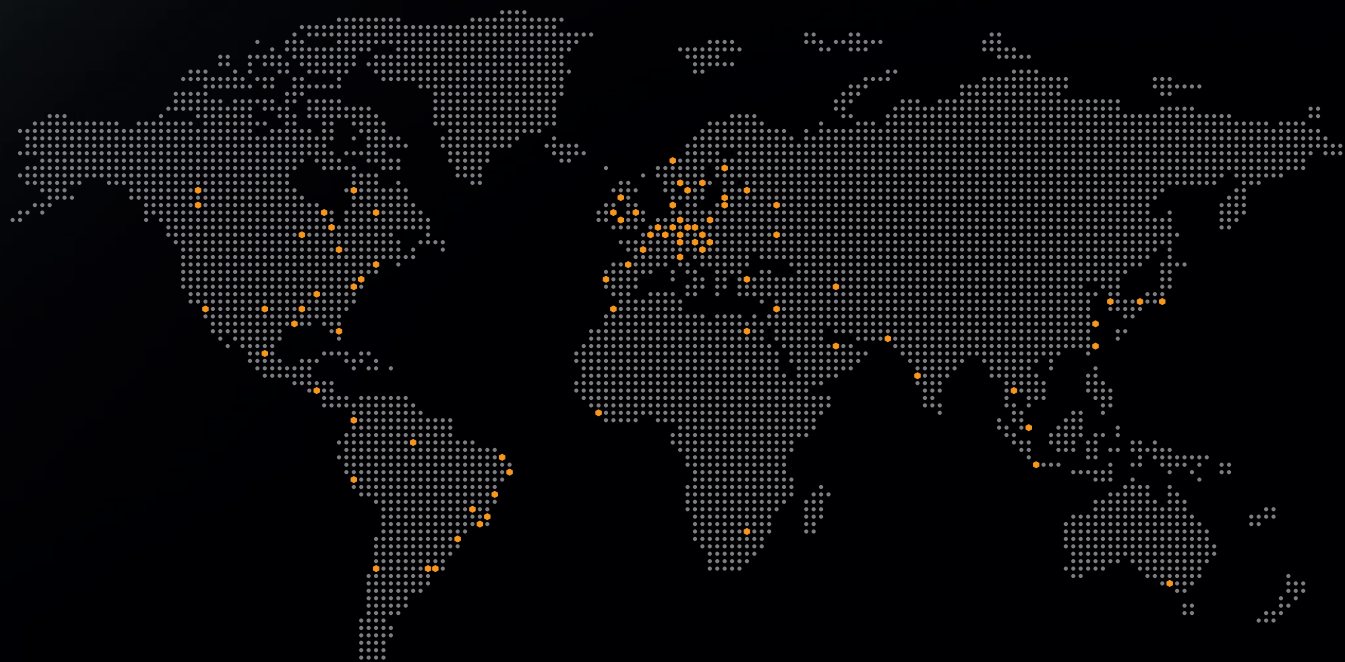

Certificates and Approvals

Being one of the first companies in the field of drive technology, KTR was certified in accordance with DIN EN ISO 9001 already in 1993, including the plants in Poland, China, India and USA.

Currently KTR products have been approved by numerous internationally renowned societies for standardization and classification. Individual approvals by other societies can be implemented on request without fail.



Original approval date:

17.05.2011

Date of the audit:

08.08.2011

Date of next recertification:

Valid until:

Date of issue: 17.06.2008

08.08.2011

Valid until:



Legend of pictograms



Torsionally rigid



Light-weight



Maintenance-free



Torsionally flexible



Axial compensation



Protected against corrosion



Highly flexible



Angular compensation



Electrically insulating



Damping vibrations

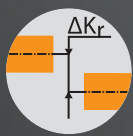

Radial compensation



Maximum speed



Axial plug-in



Shiftable at standstill



No eddy current losses



Consider shaft distance



Double-cardanic



Torque limiter slipping



Relatively short shaft distance



Radial disassembly
Ease of service



Torque limiter with synchronous ratching

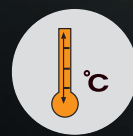

Maximum operating temperature



Standard drop-out center length



Torque limiter with idle rotation type



High speeds



Available in accordance with API



Hardened surface



Backlash-free



Complying with ATEX
For details refer to our ATEX leaflet



Accuracy X %



Shear type, separating, slipping



Certified in accordance with ABS



Consider axial displacement



Additional features compared to standard version



Headquarters

KTR Systems GmbH

Carl-Zeiss-Straße 25

D-48432 Rheine

Phone: +49 5971 798-0

Fax: +49 5971 798-698 or 798-450

E-mail: mail@ktr.com

Internet: www.ktr.com

Made for Motion 

The KTR logo is a stylized orange graphic consisting of a hexagonal shape with a pointed top and bottom, and the letters "KTR" in a bold, sans-serif font inside the hexagon.